

THERMANN™

OWNER'S MANUAL & INSTALLATION GUIDE

4 Star Gas Hot Water Heater

MODELS 135THM4N | 135THM4P
170THM4N | 170THM4P

Installation Details

Owner's Information

Warranty

For advice, repairs and service,
call: 1800 080 055



Carefully remove all packaging and transit protection from the heater before installation. Dispose of the packaging responsibly using recycling facilities where they exist.



Specifications and materials may change without notice.
Effective for all Thermann 4 star water heaters manufactured
and sold after 1st December 2013.

H4127 Rev. B

Contents

Installation Details	3
Plumbing Connections	4
Gas Connections	7
Specifications	10
Commissioning Adjustments	11
Owner's Information	12
System Maintenance	14
Troubleshooting	15
Warranty	16

Installation Details

Outdoor Tank Installation

The water heater must be installed outdoors, with the minimum clearances as shown in the figure below.

We recommend a plinth be installed under the water heater where the water heater is subjected to wet conditions.

Minimum clearance around the windows and doors must be maintained – refer to AS/NZS 5601.1.

Location

The water heater should be located as close as possible to the most frequently used hot water outlet. Ensure that the data label is clearly visible and that there is adequate access for servicing the unit.

Note: All models are equipped with a sacrificial anode, accessible through the top cover. Allow 50% of the height of the water heater for clearance above to replace the anode.

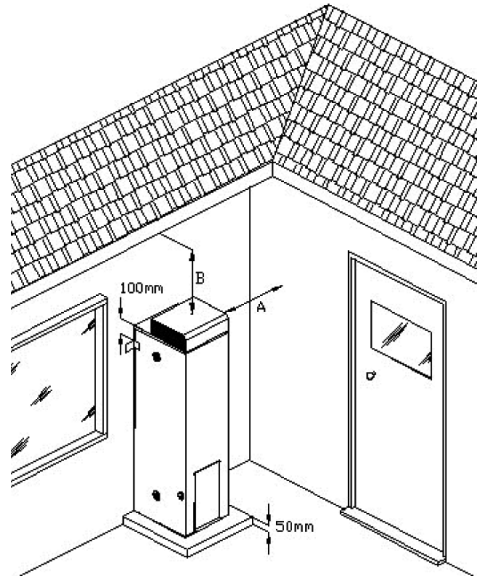

A = 500mm B=300mm min
For further details, refer to
AS/NZS 5601.1 – Gas Installations –
General Installations

Plumbing Connections

Installation Requirements

This water heater must be installed by a licensed tradesperson, and in accordance with:

- AS/NZS3500.4 "Plumbing and Drainage - Heated Water Services".
- AS/NZS 5601.1 "Gas Installations".
- Local authority regulations.
- Outside Australia, please refer to local plumbing and building codes and regulations.
- Notice to Victorian customers from the Victorian Plumbing Industry Commission – this water heater must be installed by a licensed person as required by the *Victorian Building Act (1993)*. Only a licensed person will give you a compliance certificate, showing that the work complies with all the relevant Standards and only a licensed person will have insurance protecting their workmanship for 6 years.

Water Supply Pressure

This water heater is designed for direct connection to water supply pressures of no greater than:

All Models - 1120kPa

Where the mains pressure can exceed or fluctuate beyond the pressure shown above a pressure limiting device (complying with AS1357) must be fitted in the cold water inlet supply. This device must be installed after the isolating valve and set below the pressure shown above. Note during periods of lower demand water pressure may increase.

Pool Heating

This water heater must **not** be used for pool heating.

Plumbing Connections

Pressure & Temperature Relief Valve

The Pressure & Temperature Relief Valve is supplied loose with the water heater. The valve rating is:

All Models – 1400kPa

The PTR valve must be installed directly into the top socket marked “RELIEF VALVE”. The drain line from this valve must run in a continuously downward direction in a frost-free ambient position with the discharge end left open to atmosphere permanently.

The PTR Valve is not intended to enable connection of the water heater to supplementary energy sources such as solar panels or slow combustion stoves (refer AS/NZS 3500.4 for guidance on these types of installations).

The PTR Valve must not be tampered with or removed. The water heater must not be operated unless this valve is fitted and in working order.

The PTR Valve should be checked for adequate performance or replaced at intervals not exceeding 5 years, or less in areas where local regulations apply.

Important: The PTR Valve and its drain outlet pipe must not be sealed or blocked. It is normal for the PTR valve to leak a small amount of water during heating cycles.

Danger: Failure to operate the relief valve easing lever at least once every six (6) months may result in a problem with the water heater and in some cases the tank may explode.

Warning: A separate drain line must be run for this relief valve. It is not permitted to couple drain lines from relief valves into a single common drain line.

Cold Water Connection

An approved isolating valve, non return valve, line strainer (optional but recommended), and union must be fitted between the supply main and either of the RP $\frac{3}{4}$ /20 sockets marked “INLET” at the bottom of the water heater. All fittings must be approved by the relevant Authority. See the diagram on page 6 for details.

Note: Brass plugs are supplied with the water heater to plug off the unused fittings. Ensure that a sealing material is applied to the plugs to prevent leaking.

Note for S.A. and W.A.: It is a state requirement that a Expansion Control Valve be fitted on the cold water supply line between the non return valve and the water heater. See the diagram on page 6 for details.

Plumbing Connections

Hot Water Connection

The hot water pipe should be connected to either of the RP $\frac{3}{4}$ /20 sockets marked "OUTLET" at the top of the unit. Please check local regulations regarding the use of hot water supply pipework that is not made of copper.

Insulation of Pipes

For the most economical operation of the water heater, it is recommended that all hot water lines are insulated. Where the hot water pipes are installed outdoors, the insulation should be UV stabilised.

Temperature Protection

Water heaters can produce very hot water. To reduce the risk of scald injury, it is mandatory under the requirements of Australian Standard AS/NZS3500.4 that a suitably approved temperature control device be fitted to the hot water supply to outlets used primarily for personal hygiene. This valve should be checked at regular intervals to ensure its operation and settings remain correct.

Inlet Connections

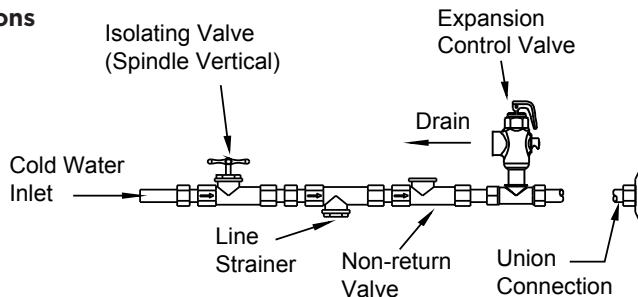

Note: a combined isolating valve/non-return valve/line strainer may be used. Expansion Control Valve only required where local regulations demand although it is recommended in areas where the water saturation index is above 0.40 (see page 12).

Gas Connections

Refer to the Data Label for correct gas type. Gas piping should be connected through the side of the case (see figure below).

The plastic grommet must be installed around the pipe and clipped into the case.

The gas control is fitted with a RC $\frac{1}{2}$ "/15 socket. A union connection should be used.

Gas pipe sizes should be in accordance with AS/NZS 5601.1.

Warning: This water heater should be checked on installation and the test point pressure set in accordance with that marked on Data Label.

Adjust gas pressure as required to achieve specified gas test point pressure. If problems are encountered in this process contact the Reece Customer Care Department on 1800 080 055.

Failure to accurately set the pressure can result in damage to the water heater, and automatically cancels the Manufacturer's Warranty. This water heater is to be installed only by an Authorised Person.

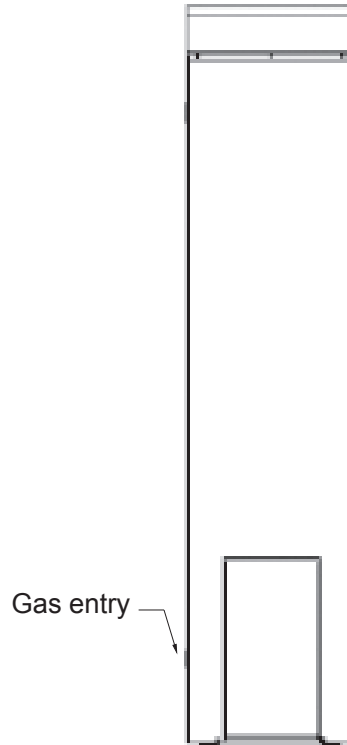

Gas Connections

Filling the Water Heater

The water heater must be filled with water before lighting.

Open all hot water taps. Open isolating valve at the cold water inlet slowly and allow water heater to fill until water flows through the system. Close each hot water tap after the air is expelled from its line.

Open the PTR Valve for approximately 10 seconds by lifting the lever on the valve to ensure water is relieved to waste through the relief drain pipe. Lower lever gently and check that it closes correctly.

Thermostat and gas control knob

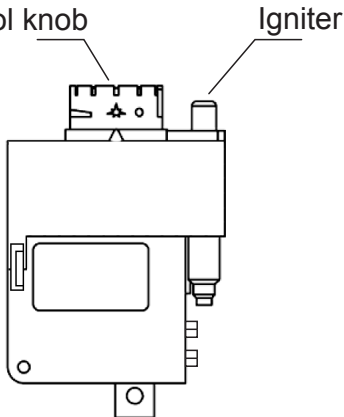

Lighting the Water Heater

Instructions for lighting procedure are on the inside of the access cover and shown below:

1. Turn the knob fully clockwise to the "•" (off) position.
2. Wait five (5) minutes so any build-up of unburnt gas can escape.
3. Turn the knob to the ★ (pilot) position.
4. Depress the knob fully (until ★ disappears below housing) and after thirty (30) seconds, whilst keeping the knob depressed, repeatedly press the igniter button (for up to 40 seconds) until the pilot flame ignites.
Note: It is not possible to depress the knob fully if the gas control has activated its safety shut-off feature. In this case, wait 60 seconds for the gas control to reset.
5. Keep the knob depressed for twenty (20) seconds after the pilot flame lights. The pilot flame can be observed if a mirror is placed directly below the pilot assembly.
6. Release the knob and check if the pilot is still alight.

Gas Connections

7. If pilot has failed to light or has not remained alight, turn gas control knob to “•” (off). Wait five (5) minutes for the escape of unburnt gas, then begin again at step 3.
8. When the pilot flame remains alight with the knob released, turn the knob anticlockwise to one of the number settings. A setting of “6” is recommended and this will give a water temperature of about 60°C.
9. Turn the knob to a higher number for higher water temperatures or a lower number for lower water temperatures.
10. Replace the access panel and ensure that it is firmly in position before operating the appliance.
11. If the burner does not light at the selected setting, the water may already be at the selected temperature.

Warning: Do not attempt to light if the pilot is out and the knob is in the “ON” position (one of the number settings). Follow steps above.

Shutting Down The Water Heater

1. Turn the knob to “•” (off) position.
2. Turn water off at water isolating valve.

Turning Off Gas To The Appliance

1. Turn the knob to “•” (off) position.
2. Turn off the gas isolation valve.

To maintain safety and efficiency this heater should be serviced annually by an authorised service agent.

Note: Instruct owner in water heater operation before leaving.

Specifications

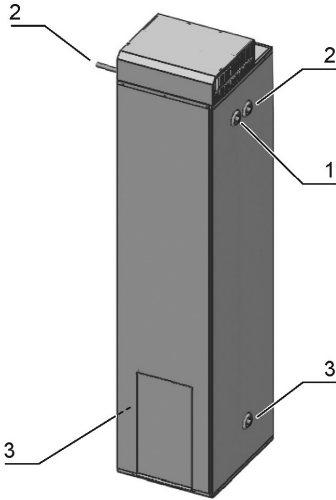

System Components	
Component	Description
1	PTR Valve
2	Hot Water Outlet To House
3	Cold Water Inlet

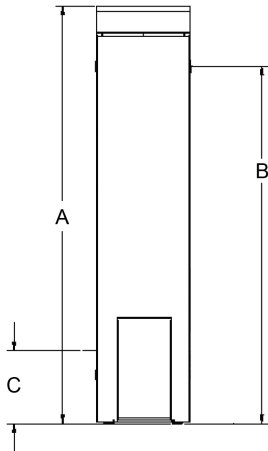
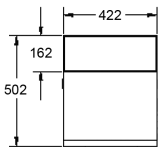

Tank Specifications		
Model Numbers	135THM4N 135THM4P	170THM4N 170THM4P
Capacity (L)	135	170
Net Weight Empty (kg)	80	86
Relief Valve Pressure (kPA)	1400	1400
Gas Consumption	135THM4N: 23.5 MJ/h 135THM4P: 22.5 MJ/h	170THM4N: 27 MJ/h 170THM4P: 26 MJ/h

Dimensions (mm)		
A - Height	1600	1895
B - Hot Water Outlet	1325	1620
C - Cold Water Inlet	220	220

Commissioning Adjustments

Note: Commissioning adjustments can be done only by a licensed tradesperson.

Main Gas Pressure Regulator Adjustment

The main burner pressure must be set at installation and should not need readjustment.

The pressure is best checked by connecting a water manometer or equivalent to the test point nipple on the gas control. The test point pressure must comply with the value on the Data Label.

If adjustment is necessary, proceed as follows:

1. Remove the securing screw (1) from the top of the Gas Control and lift the plastic cover (2) upwards.
2. Locate the regulator adjustment screw on the lower left hand side of the Gas Control (3).
3. Light the burner. Rotate adjustment screw clockwise to increase, or anti-clockwise to decrease pressure.
4. Replace the plastic cover and securing screw.

Note: For propane water heaters, the pressure adjustment is at the gas cylinder regulator. Adjustment should be conducted as required to ensure correct supply pressure to water heater as per AS/NZS 5601.1.

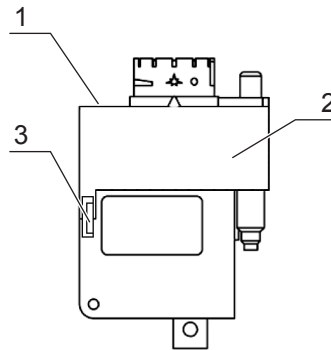

Ignition System (Spark Gap)

Check the gap between the spark electrode and the pilot burner is 3 – 5mm and adjust as necessary. Push the igniter button to test for a spark.

Warning: Test the spark gap only where there is no build up of gas.

Test The Water Heater

Test operation by lighting the water heater (see **Lighting the Water Heater**, earlier in this manual).

Owner's Information

Safety

This appliance is not intended for use by persons (including children) with reduced physical, sensory or mental capabilities, or lack of experience and knowledge, unless they have been given supervision or instruction concerning use of the appliance by a person responsible for their safety.

Children and animals should be supervised to ensure that they do not interfere with the appliance.

DO NOT place articles on or against this appliance.

DO NOT use store chemicals or flammable materials, or spray aerosols near this appliance.

DO NOT operate with panels or covers removed from the appliance.

Water Quality

Your Thermann water heater has been manufactured to suit water conditions of most Australian metropolitan supplies. Please note that harsh water supplies can have a detrimental effect on the water heater and its life expectancy. If you are unsure about your water quality you can obtain information from your local water supply authority.

The water heater is designed for use in areas where the Total Dissolved Solids (TDS) content of the water supply is less than 2500 mg/L. In areas where the TDS exceeds 600mg/L the magnesium alloy anode (supplied in the heater) may become over reactive. To alleviate this, the anode should be replaced with an aluminium alloy anode, available from your local Reece branch.

The saturation index (SI) is a measure of the corrosiveness or carbonate scaling potential of water. Negative SI indicates corrosive water that is non-scaling. The more negative the SI the more corrosive the water. Conversely, a more positive SI indicates a greater potential for scaling. If the SI is greater than 0.40 an expansion control valve should be fitted as shown in the diagram on page 6.

Owner's Information

How Long Will The Heater Run Each Day?

The length of time that the heater will run each day will vary dependent upon the amount of hot water being used by the household.

Caution: All water heaters have the ability to produce hot water in a surprisingly short time. To reduce the risk of scald injury, it is mandatory under the requirements of Australian Standards AS3500 that an Australian Standards approved temperature control valve be fitted to the hot water supply pipe work. This valve should be checked at regular intervals to ensure its operation and settings remain correct.

What Should I Do During Holidays?

If the hot water system is not used, for two weeks or more, a quantity of hydrogen gas, which is highly flammable, may accumulate in the water heater. To dissipate this gas safely, it is recommended that a hot tap be turned on for several minutes at a sink, basin or bath but not a dishwasher, clothes washer, or other appliance. During this procedure there must be no smoking, open flame or any other electrical appliance operating nearby. If hydrogen is discharged through the tap, it will probably make an unusual noise similar to air escaping.

Note: There are no user serviceable components in the system.

How Does My System Work?

The Thermann water storage tank is used to store the heated water ready for household use. It has a high temperature vitreous enamel lining to provide long life, and a high density polyurethane insulation to ensure minimal heat loss.

Never turn the gas supply off during normal use.

System Maintenance

Six Monthly Service – By Owner

Open the Pressure & Temperature Relief Valve for approximately 10 seconds by lifting the lever on the valve to ensure water is relieved to waste through the relief drain pipe. Lower lever gently and check that it closes correctly.

Other than this, personally inspecting or servicing any part of the system is not recommended.

Five Year Service – By Authorised Personnel Only

After each 5 years of operation you should contact the local service agent to replace all safety valves and anodes to ensure continued system life and operational safety. In locations where the water has a TDS greater than 600 mg/L (see Water Quality on page 12), this service is recommended every 3 years.

The five year service must be carried out by a licensed tradesperson.

The service should include the following:

- Replace the Pressure & Temperature Relief Valve.
- Replace the anode.
- Flush the water heater by doing the following:
 - i. Turn off gas and electricity supply.
 - ii. Turn off the cold water supply to the water heater at the isolating valve.
 - iii. Gently operate the easing lever on the Pressure & Temperature Relief Valve to release the pressure in the water heater.
 - iv. Disconnect the cold water inlet union to the heater and attach a drain hose.
 - v. Gently operate the Pressure & Temperature Relief Valve to let air into the heater and allow water to escape through the hose.
 - vi. Flush the heater until clear water appears then reconnect all fittings, fill the heater and restore the gas and electricity supply.

Troubleshooting

What Should I Check Before Making A Service Call?

If there is not enough hot water, it is recommended that the following points be considered before making a service call. If after checking the following points the problem has not been identified, please contact Reece Customer Care on 1800 080 055.

No Hot Water

- Confirm the water heaters gas burner and/or pilot is on and operating. If off, see lighting instructions on page 8.
- Is the Pressure & Temperature Relief Valve discharging too much water?
- Do you have the correct size water heater for your requirements? Sizing details are available from your local Reece branch.
- Is one outlet (such as the shower) using more hot water than you think?
- Carefully review the family's hot water usage and if necessary check the shower flow rates with a bucket, measuring the amount of water used over that period of time. If it is not possible to adjust water usage patterns, an inexpensive flow control valve can easily be fitted to the shower outlet.
- Replace faulty tap washers and have your plumber rectify any leaking pipe work.
- Consider that often the hot water usage of showers, washing machines and dishwashers can be under estimated. Review these appliances to determine if your daily usage is greater than the capability of your water heater.
- Is there a leaking hot water pipe or dripping hot water tap? A small leak can waste a large quantity of hot water.

Water Discharge from the PTR Valve

It is normal for the PTR to allow a small quantity of water to escape during the heating cycle. The amount of discharge will depend on hot water usage.

Continuous trickle (PTR)

This is most likely due to a build up of foreign matter. In this case try gently raising the easing lever on the Pressure & Temperature Relief Valve for a few seconds then release gently. This may dislodge a small particle of foreign matter and rectify the fault.

Steady flow (PTR) - more than 20L per day

This may be caused by excessive water supply pressure, a faulty Pressure & Temperature Relief Valve or a faulty gas control. Turn off the gas supply and contact your licensed plumber.

Warranty

Thermann Hot Water Unit

Manufactured by GWA Group Limited ("GWA")

Terms of Warranty and Replacement Guarantee

All Thermann water heaters manufactured and sold after 31 December 2011 are backed by a comprehensive one (1) year full parts and labour warranty (conditions apply – see below).

Furthermore, the Thermann tank includes a guarantee to replace your hot water unit if the inner cylinder fails within seven (7) years (conditions apply – see below).

The terms of the Warranty and replacement guarantee are set out below.

1 Year Comprehensive Warranty

Your hot water system and its components ("Unit") are covered by 1 year (parts and labour) warranty against defective factory materials or workmanship.

This warranty period commences from the date of installation of the Unit providing you have proof of this installation date. Where the date of completion of installation is not known or cannot be proven, then this warranty will commence one (1) month after the date of manufacture (refer to the data label on the unit).

Replacement Guarantee

If an inner cylinder fails on a Thermann hot water unit within a further six (6) years after the end of the initial one (1) year warranty period, GWA will provide a free replacement hot water unit at the nearest approved GWA agent or GWA office to the owner's home. Under this replacement guarantee, the transport, installation and labour costs of delivering the replacement hot water unit and removing and replacing the existing hot water unit with the replacement hot water unit will be the responsibility of the owner of the existing hot water unit.

Conditions of Warranty and Replacement Guarantee

The benefits provided to you by the warranty and replacement guarantee (collectively "Warranty") are in addition to the guarantees and other rights and remedies available to you under the Australian Consumer Law ("ACL").

If the Unit fails to conform to this Warranty during the applicable period, GWA will replace any failed component or where necessary, in the absolute discretion of GWA, replace the Unit free of charge including reasonable labour costs incurred in normal business working hours.

This Warranty only applies to defects which have arisen solely from faulty materials or workmanship in the Unit and does not apply to other defects which may have arisen as a result of, without limitation, the following:

Warranty

accidental damage, abuse, misuse, maltreatment, abnormal stress or strain, harsh or adverse water conditions including excessive water pressure or temperature, neglect of any kind or otherwise as a result of any use of the Unit contrary to the product manual or other instructions provided with this water heater. Alterations or repair of the Unit other than by an accredited and licensed service agent or technician are not covered. Attachment of accessories or use of non genuine replacement parts other than those manufactured or approved by GWA are not covered by this Warranty.

This Warranty applies only to the Unit and does not cover any ancillary plumbing or electrical parts supplied by the installer such as pressure limiting valve, tempering valve, line strainer, stop cocks, non-return valve, electrical switches, pumps or fuses, or faulty installation.

The Unit must be installed by a licensed plumber in accordance with information set out in the Owner's Manual and/or Installer's Guide supplied with the Unit and/or any relevant statutory requirements.

In addition to this Warranty, certain legislation (including the ACL) may give you rights which cannot be excluded, restricted or modified. This Warranty must be read subject to such legislation and nothing in this Warranty has the effect of excluding, restricting or modifying those rights.

If GWA fails to meet a guarantee under the ACL, your remedy for such failure may be limited to any one or more of the following:

- replacement of the Unit;
- repair of the Unit;
- refunding the cost of the Unit;
- payment of reasonable costs of having the Unit repaired;
- payment in respect of the reduced value of the Unit.

Any defective part of the Unit must be returned to the point of sale before replacement can be considered under the terms of this Warranty. If the costs of returning any defective parts are unreasonable, please contact GWA on 1300 412 612 so that we can arrange a collection if appropriate.

Warranty claims can be made at the point of sale or by posting a warranty claim to GWA (contact details listed below) within one (1) month of the appearance of a defect. Warranty claims under this extended warranty must include the following details:

- Date of Purchase;
- Location of Purchase;
- Proof of Purchase;
- Date of Installation;
- Contact Details
- Product Serial Number

Business Address

GWA Group Limited
Level 1, 7-9 Irvine Place
Bella Vista, NSW 2151, Australia
Telephone: 1300 412 612

Warranty

Note: If the Unit is located in a position that does not comply with the installation instructions or relevant statutory requirements, then this Warranty does not cover major dismantling or removal of cupboards, doors, walls or special equipment and/or excessive labour, at the determination of GWA, to make the Unit accessible for repair or replacement.

As required by legislation, including under the ACL, any claims for damage to furniture, carpets, walls, foundations or any other consequential loss either directly or indirectly due to defects of any kind in a Unit will only be met by GWA where the damage could be considered reasonably foreseeable.

Our goods come with guarantees that cannot be excluded under the Australian Consumer Law. You are entitled to a replacement or refund for a major failure and for compensation for any other reasonably foreseeable loss or damage. You are also entitled to have the goods repaired or replaced if the goods fail to be of acceptable quality and the failure does not amount to a major failure.



For advice, repairs and service,
call: **1800 080 055**

Serial Number