



prodigy[®] 4

gas storage specifications

thinkeasyinstall

Easy replacement of existing 3 star external gas storage systems

thinkvalue

Backed by a 7 year tank warranty[^]



1300 365 116
www.dux.com.au

prodigy[®] 4 gas storage

Why you should choose a Dux Prodigy[®] 4 gas storage system

- Backed by a 7 year tank warranty*, including 1 year parts and labour
- 4 star efficiency
- Full mains pressure to all taps
- Adjustable thermostat for safety, efficiency and control over operating costs and performance
- Rapid reheat
- Same footprint as existing 3 star gas storage, allowing easy replacement of older systems
- Available in both natural gas and propane
- Duro-name[®] tank lining for corrosion protection
- Dux is part of a publicly listed Australian company



Which Dux gas storage system is right for you?

CAPACITY (LITRES)	PEOPLE
135	3-5
170	4-6



Adult icon can represent dishwasher or washing machine. An adult icon does not represent a spa bath.

SPECIFICATIONS	135ZN/135ZL	170ZN/170ZL
Nominal Capacity (Litres)	135	170
Net Weight Empty (kg)	72	86
Relief Valve Pressure (kPa)	1400	1400
Gas Consumption (MJ/hr)	135ZN: 23.5 135ZL: 22.5	170ZN: 27 170ZL: 26
Energy Star Rating	★★★★	★★★★

NOMINAL DIMENSIONS (MM)	135ZN/135ZL	170ZN/170ZL
A Overall Height Outdoor	1601	1896
B Hot Water Outlet	1327	1620
C Cold Water Inlet	221	221
Gas Inlet	336	336

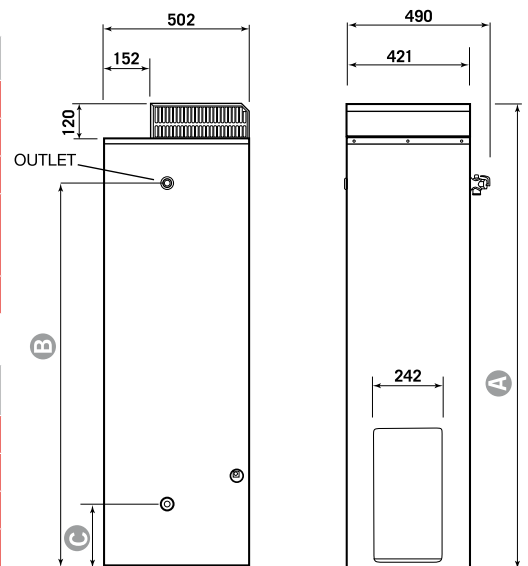

Warranty: Warranty terms and conditions are in the product's Owners Manual, visit www.dux.com.au/warranty-terms for full details and conditions which apply.



Contact Dux for your Hot Water Solutions

Sales: 1300 365 116 Service: 1300 365 115 Web Site: www.dux.com.au
 ©Dux Manufacturing Limited ABN 19 077 879 844. Lackey Rd, PO Box 209 Moss Vale, NSW 2577
 The information supplied was correct at time of printing. Specification and materials may change without notice.
 ® and ™ indicate trademarks of Dux Manufacturing Limited. Dux Manufacturing Limited is part of a publicly listed Australian company.

