

Gas Heaters

GWH 10-2 G.. / GWH 13-2 G.. / GWH 16-2 G..



BOSCH

en Installation Manual and Operating Instructions



Read installation manual prior to installation of this unit!
Read user manual before putting this unit in operation!



Observe the warnings in the manuals!
The installation room must fulfill the ventilation requirements!



Installation by an authorised person only!

Table of contents

1	Key to symbols and safety instructions	3		
1.1	Explanation of symbols	3		
1.2	Safety information	3		
2	Technical Characteristics and Dimensions	4		
2.1	General Description	4		
2.2	Explanation of Model Code	4		
2.3	Package contents	4		
2.4	Description of the heater	4		
2.5	Dimensions	5		
2.6	Functional diagram of the heater	6		
2.7	Electrical diagram	7		
2.8	Function	7		
2.9	Technical characteristics	8		
3	Regulations	9		
4	Installation	10		
4.1	Important information	10		
4.2	Selection of the place of installation	10		
4.3	Heater mounting	11		
4.4	Water connection	11		
4.5	Hydrogenerator operation	11		
4.6	Pressure Relief	12		
4.7	Gas connection	12		
4.8	Testing	12		
5	Operating instructions	13		
5.1	Digital display - description	13		
5.2	Before starting up the heater	13		
5.3	Turning the heater on and off	13		
5.4	Water flow	13		
5.5	Gas adjustment	14		
5.6	Temperature/flow adjustment	14		
5.7	Draining the appliance	14		
6	Commissioning	15		
6.1	Inlet pressure adjustment	15		
6.2	Burner pressure adjustment	15		
6.3	Conversion to a different type of gas	15		
7	Maintenance	16		
7.1	Flue gas safety device	16		
8	Problems	17		
8.1	Problem/cause/solution	17		
9	Environmental protection	19		
			10	Water quality 20
			11	Warranty details 21

1 Key to symbols and safety instructions

1.1 Explanation of symbols

Warnings

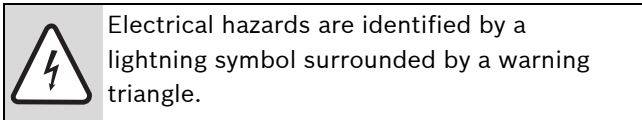
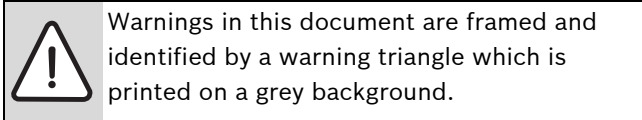

Keywords indicate the seriousness of the hazard in terms of the consequences of not following the safety instructions.

- **NOTICE** indicates that material damage may occur.
- **CAUTION** indicates that minor to medium injury may occur.
- **WARNING** indicates that serious injury may occur.
- **DANGER** indicates possible risk to life.

Important information

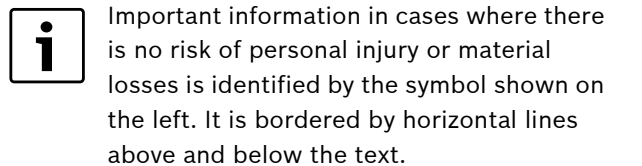

Additional symbols

Symbol	Meaning
▶	a step in an action sequence
→	a reference to a related part in the document or to other related documents
•	a list entry
–	a list entry (second level)

Table 1

1.2 Safety information

If you smell gas:

- ▶ Close the gas supply valve.
- ▶ Open the windows.
- ▶ Do not operate any electrical appliances or switches (on/off).
- ▶ Extinguish other sources of ignition.
- ▶ Go to a different location and call the gas supplier or an authorised technician.

If you smell combustion gases:

- ▶ Turn off the heater.
- ▶ Open doors and windows.
- ▶ Notify an authorised technician.

Assembly, modifications

- ▶ The assembly and modifications to the heater can only be performed by an authorised installer.
- ▶ Do not modify the pipes which conduct combustion gases.
- ▶ Do not close or reduce air circulation vents.

Maintenance

- ▶ We recommend the system be serviced regularly to ensure it functions reliably and safely.
- ▶ The installer is responsible for the safety and environmental compatibility of the installation.
- ▶ The heater should be serviced annually.
- ▶ Only original spare parts must be used.

Explosive and highly inflammable material

- ▶ Do not store or use inflammable material (paper, solvents, paints, etc) near the heater.

Combustion air and surrounding air

- ▶ To avoid corrosion, the combustion air and surrounding air must be free from harmful substances (e.g. halogenated hydrocarbons which contain chlorine and fluorine compounds).
- ▶ Do not spray pressure pack or use chemicals around the heater

Information to the customer

- ▶ Inform the customer about how to operate the heater.
- ▶ This appliance is not intended for use by persons (including children) with reduced physical sensory or mental capabilities. Children should be supervised to ensure they do not play with the appliance.
- ▶ Caution customers against performing modifications or repairs themselves.

To be installed and serviced only by an authorised person

The “authorised installing person” is responsible for:

- ▶ Correct commissioning of this appliance.
- ▶ Ensuring the appliance performs to the specifications stated on the rating label.
- ▶ Demonstrating the operation of the appliance to the customer before leaving.
- ▶ Handing these instructions to customer.

THIS APPLIANCE IS NOT FOR USE AS A POOL OR SPA POOL HEATER.

THIS APPLIANCE IS ONLY TO BE INSTALLED INDOORS.

2 Technical Characteristics and Dimensions

2.1 General Description

Model	GWH 10/13/16 -2 G..
Category	CONTINUOUS FLOW
Type	INTERNAL

Table 2

2.2 Explanation of Model Code

Type	l/min	Series	Ignition	Gas Types
GWH	10	2	G	NG / LP gas
GWH	13	2	G	NG / LP gas
GWH	16	2	G	NG / LP gas

Table 3

2.3 Package contents

- Gas heater
- Fixing Brackets
- flexible water pipes
- Gas regulator
- Heater documentation

2.4 Description of the heater

Designed for convenience, the heater is ready to operate by simply pressing a switch.

- Heater for wall-mounting
- Ignition by electronic device triggered when the water valve opens
- Hydrodynamic generator produces sufficient energy to ignite and control the heater.
- Gauge to display temperature, burner operation and error codes
- Temperature sensor to monitor the water temperature at the heater outlet
- Available in Natural gas or LP gas
- Temporary pilot burner which only functions during the period between the opening of the water valve and the ignition of the main burner
- Water valve made of fibreglass-reinforced polyamide, and is 100% recyclable
- Automatic control of the water flow to allow for variable water supply pressure.

- Gas flow adjustment proportional to the water flow to maintain a constant temperature.
- Safety devices:
 - Ionisation probe to check for accidental extinction of the burner flame
 - Flue gas safety device which turns off the heater in cases where the evacuation of flue gases is inadequate
 - Overtemperature switch which prevents overheating of the heat exchanger.

2.5 Dimensions

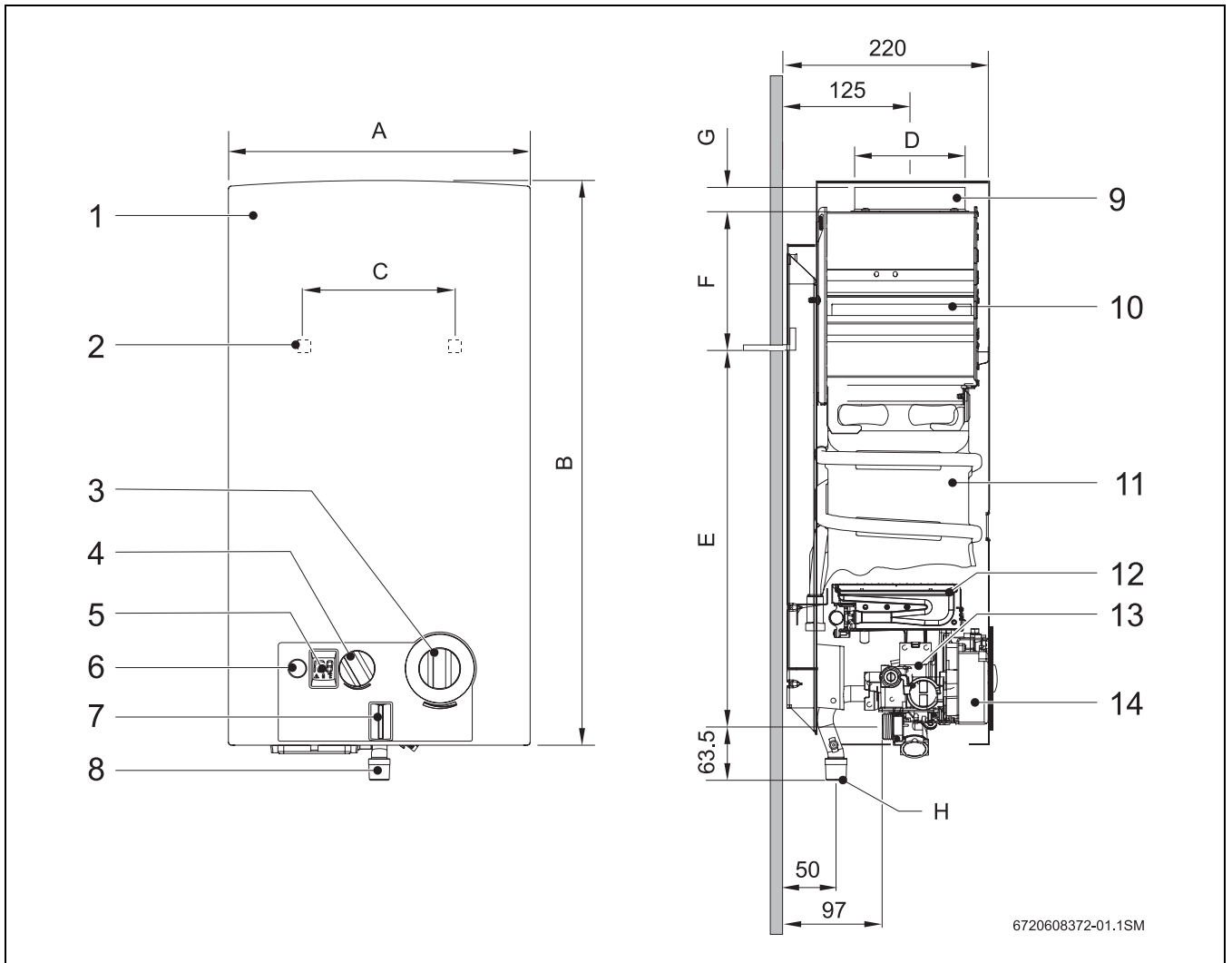

Fig. 1

- | | |
|---|-------------------------------------|
| 1 Front cover | 8 Gas connection |
| 2 Opening in rear panel for mounting on the wall | 9 Connection collar for flue |
| 3 Temperature/volume selector | 10 Draught diverter |
| 4 Gas adjustment | 11 Copper Heat exchanger |
| 5 Digital display | 12 Burner |
| 6 Switch/LED - Low water pressure indicator | 13 Gas valve |
| 7 LED - Burner status check | 14 Ignition unit |

Dimensions (mm)	A	B	C	D	E	F	G	H (Ø)	
								Natural gas	LP gas
GWH10...	310	580	228	115	463	60	25	20	15
GWH13...	350	655	228	140	510	95	30	20	15
GWH16...	425	655	334	140	540	65	30	20	15

Table 4 Dimensions

2.6 Functional diagram of the heater

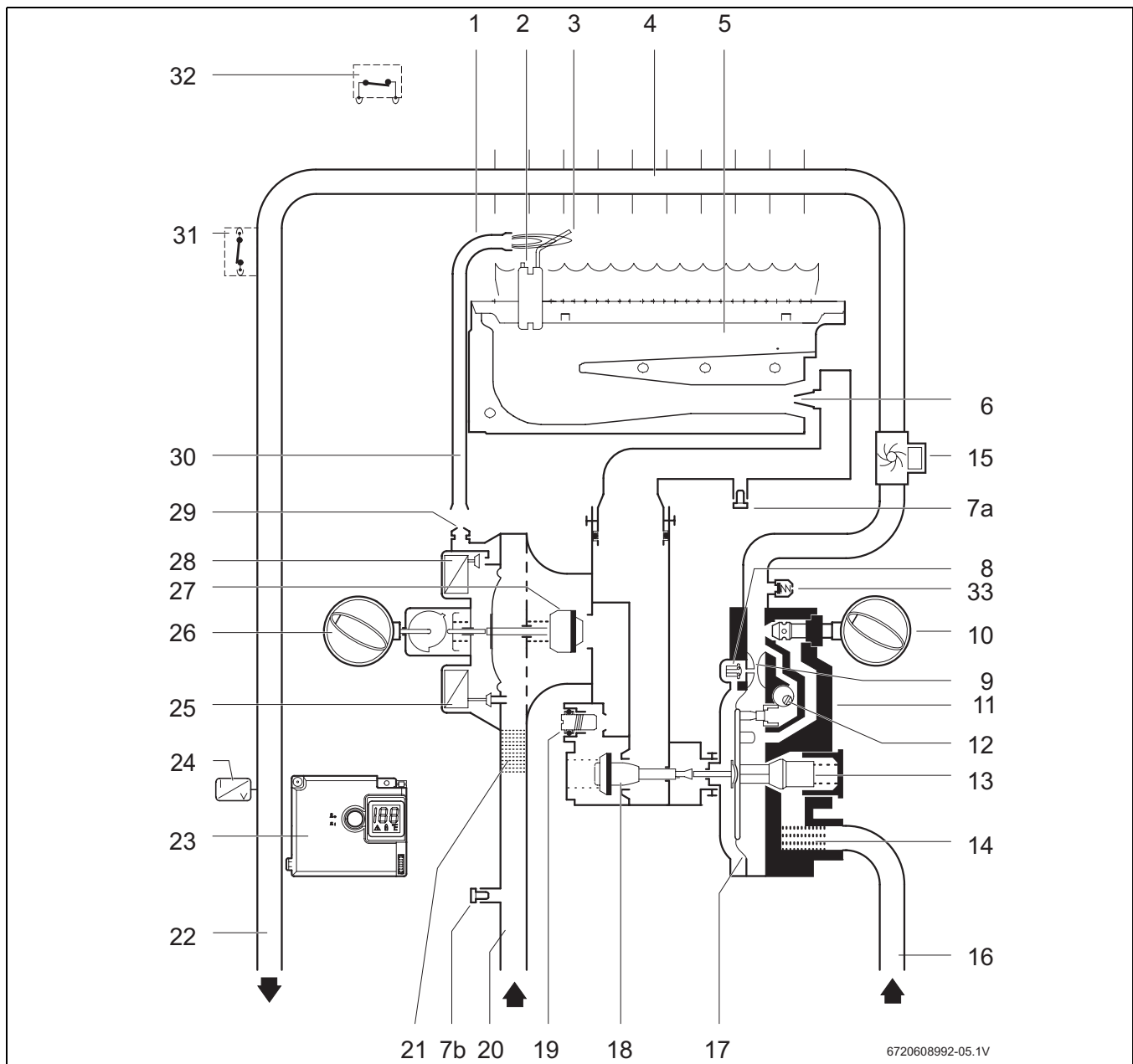

Fig. 2 Functional diagram

- | | | | |
|----|-------------------------------|----|-----------------------------|
| 1 | Pilot burner | 17 | Diaphragm |
| 2 | Ignition Electrode | 18 | Main gas valve |
| 3 | Ionisation probe | 19 | Maximum gas adjusting screw |
| 4 | Heat exchanger | 20 | Gas supply pipe |
| 5 | Main burner | 21 | Gas filter |
| 6 | Injector | 22 | Hot water pipe |
| 7a | Burner pressure test point | 23 | Ignition unit |
| 7b | Gas inlet pressure test point | 24 | Temperature sensor |
| 8 | Slow ignition valve | 25 | Servo valve |
| 9 | Venturi | 26 | Power selector |
| 10 | Temperature/volume selector | 27 | Gas valve |
| 11 | Water valve | 28 | Pilot valve |
| 12 | Plunger | 29 | Pilot injector |
| 13 | Water flow regulator | 30 | Pilot gas pipe |
| 14 | Water filter | 31 | Overtemperature switch |
| 15 | Hydrogenerator | 32 | Flue gas safety device |
| 16 | Cold water pipe | 33 | Relief Valve/Drain screw |

2.7 Electrical diagram

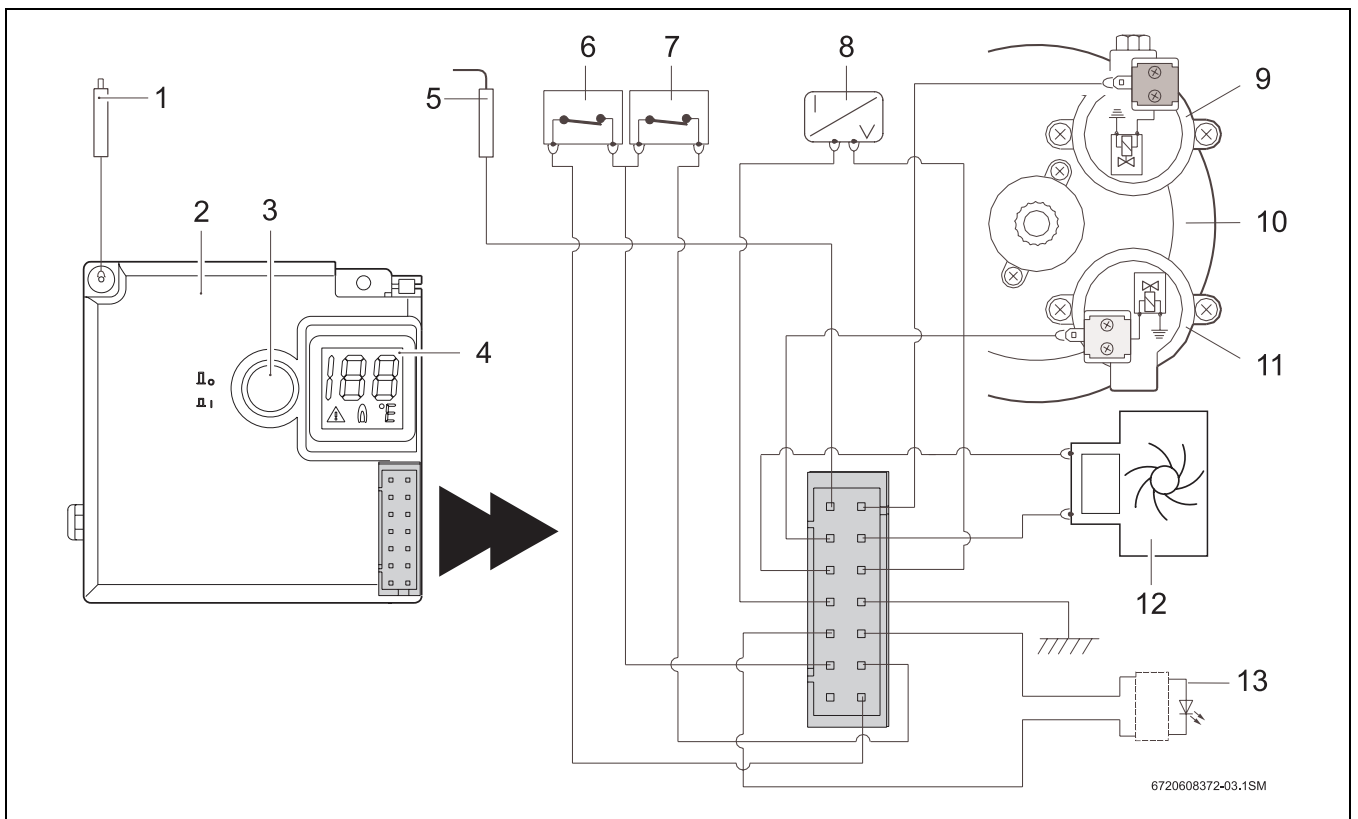

Fig. 3 Electrical diagram

- | | |
|---|--|
| <p>1 Ignition electrode
 2 Ignition unit
 3 Switch/LED - Low water pressure indicator
 4 Digital display
 5 Ionisation probe
 6 Flue gas safety device
 7 Overtemperature switch</p> | <p>8 Temperature sensor
 9 Pilot solenoid (Normally Closed)
 10 Diaphragm valve
 11 Main Solenoid (Normally Open)
 12 Hydrogenerator
 13 LED - Burner status check</p> |
|---|--|

2.8 Function

This gas heater is equipped with automatic electronic ignition to simplify operation.

► To activate, just turn on the switch (Fig. 8).

After this, automatic ignition occurs whenever a hot water tap is opened. First, the pilot burner is lit and approximately four seconds later the main burner ignites. The pilot burner flame is extinguished after the main burner lights.

This is a way of saving a great amount of energy as the pilot burner only operates for the minimum necessary time to ignite the main burner.

2.9 Technical characteristics

Technical characteristics	Units	GWH10	GWH13	GWH16
Gas Consumption				
Nominal Gas Consumption	MJ	79	100 (NG)	127
			97 (LP gas)	
Supply pressure				
Natural gas H	kPa	1.13	1.13	1.13
LP gas	kPa	2.75	2.75	2.75
Number of injectors		12	14	18
Water data				
Maximum permissible pressure	kPa	1000	1000	1000
Temperature selector in fully clockwise position				
Temperature rise	°C	50	50	50
Flow range	l/min	2.2 - 4.6	2.2 - 6.2	2.2 - 8.6
Minimum operating pressure	kPa	35	35	50
Minimum pressure for maximum flow	kPa	50	60	80
Temperature selector in fully anti-clockwise position				
Temperature rise	°C	25	25	25
Flow range	l/min	4 - 10	4 - 13	4 - 15
Minimum operating pressure	kPa	45	45	50
Minimum pressure for maximum flow	kPa	100	140	170

Table 5

3 Regulations

Any local by-laws and regulations pertaining to installation and use of gas-heated appliances must be observed.

This appliance must be installed in accordance with the manufacturers installation instructions, AS5601, NZ5261 and all Local Building & Gas fitting regulations

It is recommended that for sanitary fixtures used for the purpose of personal hygiene, that a temperature limiting device be fitted (such as a tempering valve) as per AS3498.

This appliance must not be installed in a bedroom, bathroom, toilet, or combined living/sleeping room as per AS5601 5.12.5.2

Failure to install this appliance in accordance with these installation instructions will void the warranty.

4 Installation



DANGER:

This appliance must not be installed in a bedroom, bathroom, toilet or combined living/sleeping room in accordance with AS5601.



DANGER: Explosion Risk

- ▶ Always turn off the gas cock before carrying out any work on components which carry gas.



The gas installation, connection of the flue and supply pipes, as well as the initial startup are to be performed exclusively by an authorised person.



This appliance should only be installed in applications where cold water temperature does not exceed 40 °C.



The use of these heaters with water supply pressure values below 50 kPa is not recommended. This appliance requires a minimum flow rate of 2.5lpm to operate. Water fixtures with a flow rate of 6lpm for hand basins and 8.5lpm for shower roses are recommended.



Installation in a marine environment should be avoided.



Not suitable for pool, spa pool or solar application.

4.1 Important information

- ▶ Install in accordance with AS5601, AS/NZS3500.4.2, NZS5261 and all local building, water and gas fitting regulations particularly with regard to ventilation requirements.
- ▶ Install gas and water isolation valves as close as possible to the heater.
- ▶ After finishing the gas piping system, the pipes must be thoroughly purged and leak-tested. To avoid damaging the gas valve by excess pressure, this test must be performed with the gas valve of the heater closed.

- ▶ Check if the heater corresponds to the type of gas provided.
- ▶ Ensure the flow and pressure through the regulator are appropriate for the consumption of the heater (see technical data in the table 5).

4.2 Selection of the place of installation

Requirements regarding the place of installation

- Comply with the specific instructions for each State.
- Install the gas heater in a well-ventilated location where it will not be exposed to temperatures below zero. Ensure combustion gases are flued to outside atmosphere in accordance with AS5601.
- To avoid corrosion, the combustion air must be free from harmful substances. Examples of particularly corrosive substances: halogenated hydrocarbons contained in solvents, paints, glues, hairsprays and various domestic detergents. If necessary, take adequate measures.
- Install the appliance in accordance with the minimum installation clearances indicated in Fig. 4.
- The gas heater must not be installed over a heat source.
- Do not obstruct the openings at top and bottom of appliance.
- Top and bottom areas must be clear from any obstacles at least 30 cm.

In case of a frost risk:

- ▶ Turn off the heater.
- ▶ Drain the heater (see section 5.7)

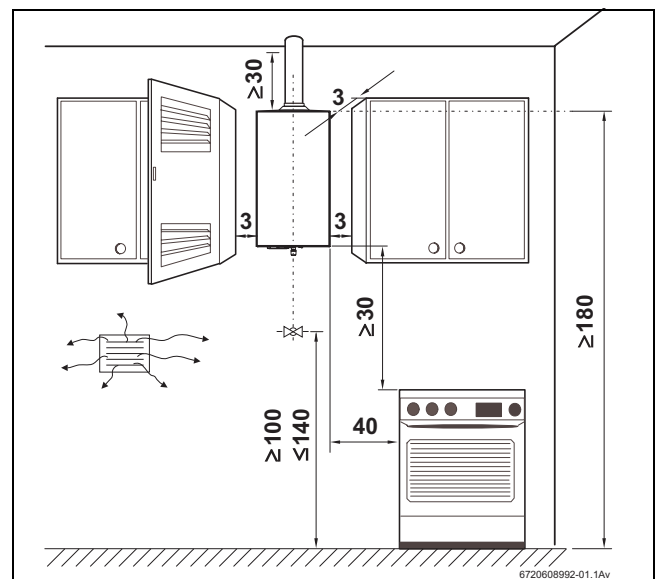

Fig. 4 Minimum clearances



Ventilation requirements as per AS5601.

Combustion gases



Use single or twin skin flue in accordance with AS5601.



DANGER: Make sure that all flue connections are sealed.

- ▶ Fit the flue pipe with an approved flue cowl.
- ▶ Failure to follow this requirement may cause dangerous exhaust gases to enter living space which may result in personal injury or loss of life.



DANGER:

Every part of the flue system must be in the vertical plane.



CAUTION:

Ensure that the flue is installed to the requirements of AS5601, including the requirement to terminate the flue above the roof level.

If any of these conditions cannot be met, a different location must be selected.

Surface temperature

The maximum surface temperature of the heater is less than 85 °C, with the exception of the flue piping. No special protection measures are required for flammable construction materials or built-in furniture items.

Air intake

The place where the heater is to be installed must have an adequate air supply as per AS5601.

4.3 Heater mounting

- ▶ Remove the temperature/flow selector and the gas selector knobs.
- ▶ Unscrew the cover fixing screws.
- ▶ With a simultaneous movement forwards and upwards, release the cover from the two lugs at the back.
- ▶ Fix the heater vertically, using the provided screw hooks and plugs or use fixings appropriate for the material & weight.



CAUTION:

Never support the gas heater on the water or gas connections.

4.4 Water connection

It is advisable to purge the water pipes before connection, because the presence of dirt may reduce the flow and, in extreme cases, cause a blockage.

- ▶ Identify the cold water pipe (Fig. 5, item A) and the hot water pipe (Fig. 5, item B), so as to avoid any possible cross-connection.
- ▶ Connect the water pipes to the water valve using the connection accessories provided.

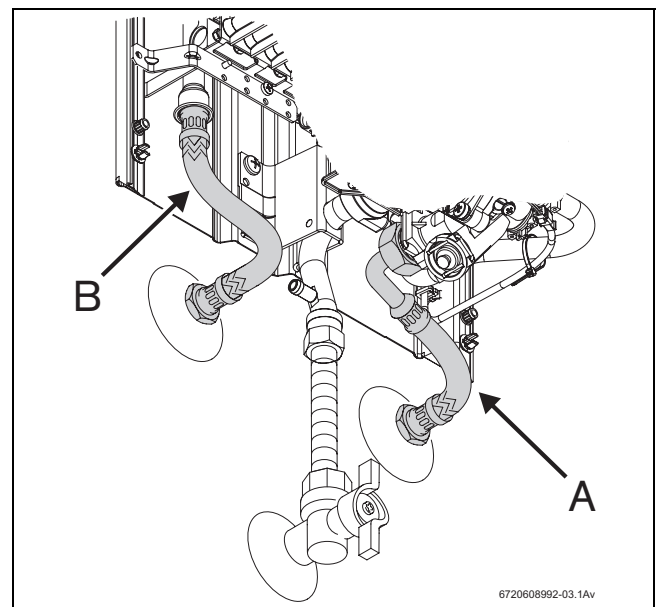

Fig. 5 Water connection



CAUTION:

If fitting an isolating valve to the water inlet line it must be a Gate or Ball Valve, a Stop Cock or Non-Return Valve must not be fitted.

4.5 Hydrogenerator operation

The hydrogenerator (hydrodynamic generator or HDG) is located in the water circuit between the water valve and the heat exchanger. This component has a turbine that rotates when water flows past its blades. This movement is transmitted to an electric generator which powers the heater ignition unit.

The electrical voltage value supplied by the HDG is approximately 3.0 VAC.

4.6 Pressure Relief

The pressure relief (Fig. 2, pos. 33) will release pressure from the system whenever the value exceeds 1500 kPa.

4.7 Gas connection



DANGER:

If local regulations are not followed, a fire or explosion could result causing property damage, personal injury, or loss of life.



Size gas supply as per AS5601.

Incorrect gas pipe sizing will not be covered by the warranty.

Gas regulator

The appliance is supplied with a gas pressure regulator that must be installed on the heater before attaching the gas supply line (see Fig. 6).

- ▶ Use sealing tape to assure the complete tightness of the installation.

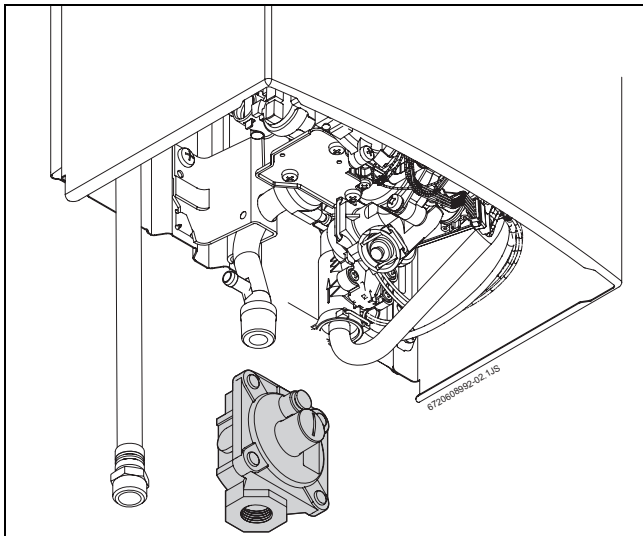

Fig. 6 Gas regulator

4.8 Testing

- ▶ Turn on the gas and water cocks and check all connections for leaks. If all connections are sound then follow procedures set out in Section 6 for adjustment of Gas Pressures.

5 Operating instructions



Open all water and gas isolation valves.
Purge the pipes.



CAUTION:

The front stainless steel panel in the burner and pilot burner area may reach high temperatures, with risk of burning in case of contact, and must not be removed.

5.1 Digital display - description

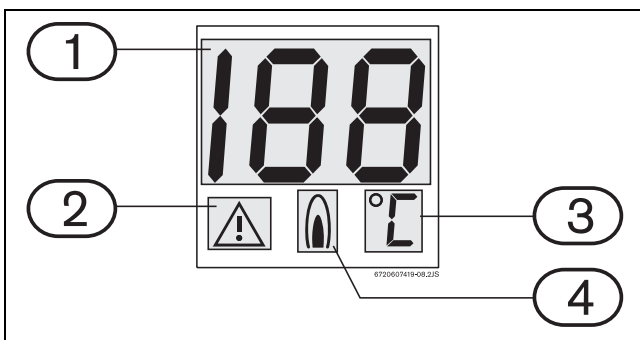

Fig. 7 Digital display

- 1 Temperature/error code
- 2 Malfunction indicator
- 3 Temperature measurement units
- 4 Heater in operation (burner turned on)

5.2 Before starting up the heater



CAUTION:

▶ Initial startup must be performed by an authorised gas fitter who will provide the customer with all the necessary information for optimum operation of the gas heater.

- ▶ Check if the gas indicated on the rating plate is the same as the one used at the location.
- ▶ Open the gas valve.
- ▶ Open the water valve.

5.3 Turning the heater on and off

Turning on

- ▶ Press the switch , position .

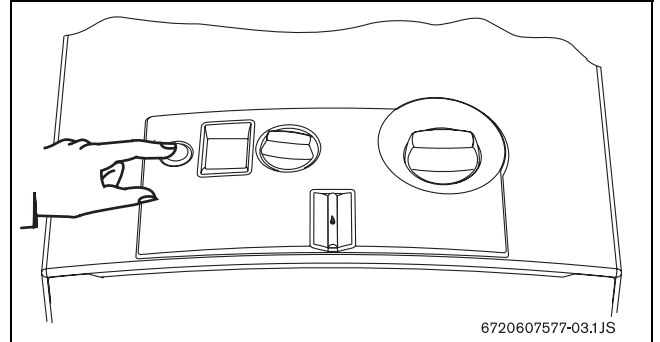

Fig. 8

Turn Hot Tap on, LED light on = Main burner on

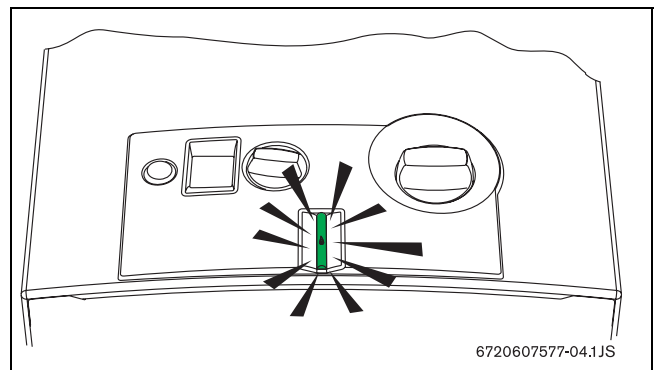

Fig. 9

Turning off

- ▶ Press the switch , position .

5.4 Water flow

If the red LED starts flashing during operation, check the water flow.

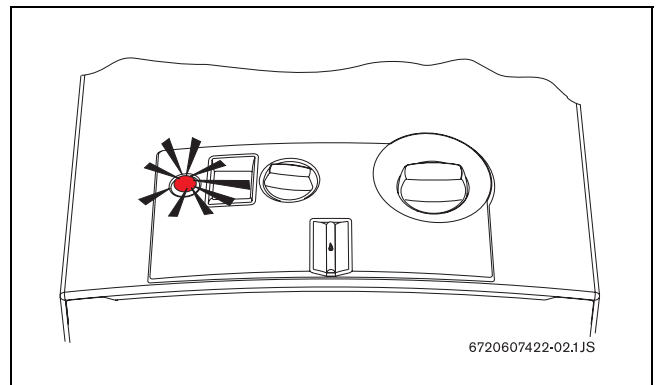

Fig. 10

5.5 Gas adjustment

Lower water temperature.
Use less gas.

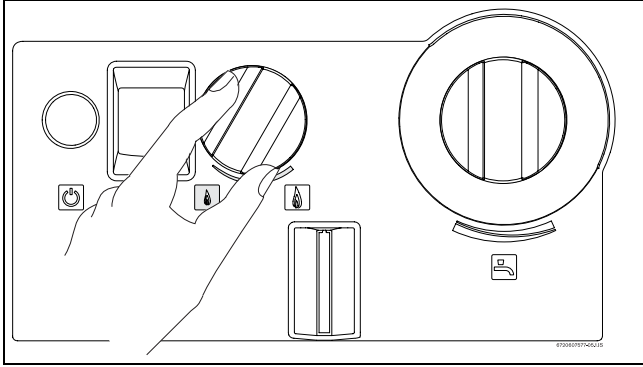

Fig. 11

Higher water temperature.
Use more gas.

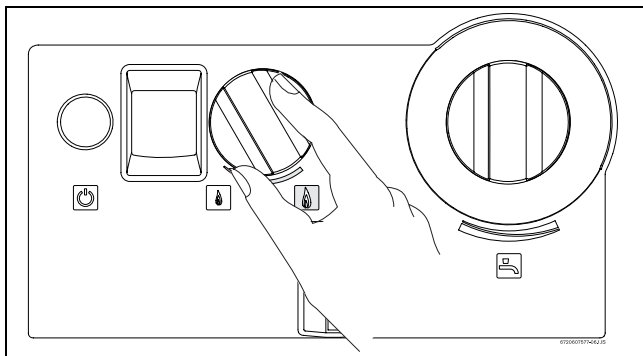

Fig. 12

5.6 Temperature/flow adjustment

- ▶ Turn anti-clockwise
Increases flow and decreases water temperature.

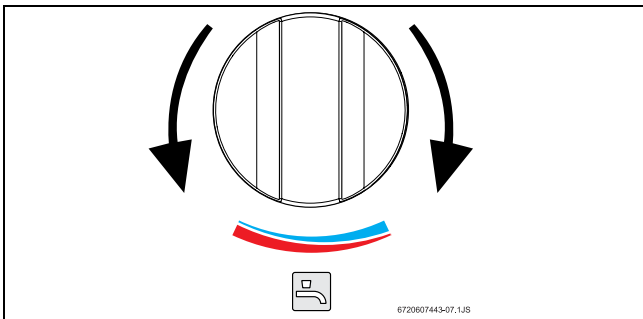

Fig. 13

- ▶ Turn clockwise.
Decreases flow and increases water temperature.

Regulating the temperature to the minimum required value reduces energy consumption.



CAUTION:

The temperature on the display is not precise, always check before bathing children or elderly people.

5.7 Draining the appliance

There are two ways to drain the appliance if there is a risk of freezing.

After turning off the inlet water valve and gas supply, open a hot water tap to relieve pressure then proceed as follows:

Water valve draining (see fig 14)

- ▶ Remove the fixing lock from the filter screw cap (no. 1) situated in the water valve.
- ▶ Remove the filter screw cap (no. 2) from the water valve.
- ▶ Empty all the water contained in the heater.

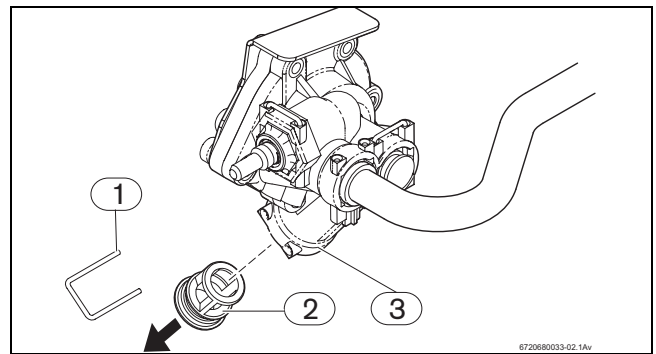

Fig. 14 Draining

- 1 Lock
- 2 Filter screw cap
- 3 Water valve

Cold water inlet pipe drain (see fig 15)

- ▶ Remove the pressure relief screw (no. 1) situated in the water inlet pipe.
- ▶ Drain all the water contained in the heater.

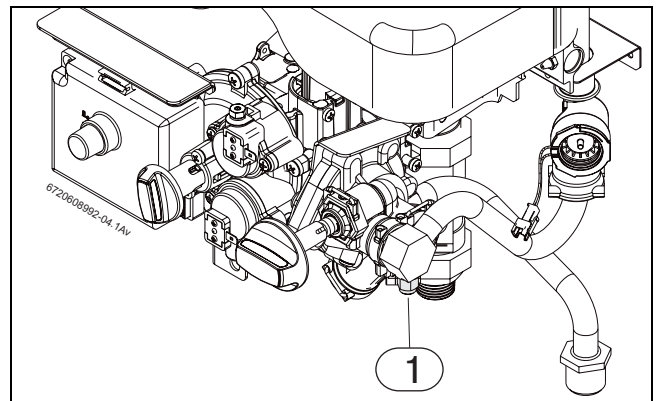

Fig. 15 Draining

- 1 pressure relief screw

6 Commissioning

6.1 Inlet pressure adjustment



DANGER:

The following procedures must only be performed by a qualified technician.

Burner pressures have been adjusted in the factory, however adjustment may be required upon installation.

Attach a manometer to the inlet pressure test point located on the gas inlet pipe.

Inlet gas pressure should be adjusted at the appliance regulator to 1.13 kPa for Natural Gas and 2.75 kPa for LP gas.

These measurements must be set while the unit is operating.

6.2 Burner pressure adjustment

Accessing the adjusting screw

- ▶ Remove the front cover from the heater (see 4.3).

Connecting the manometer

- ▶ loosen the burner test point captive screw (Fig. 16).
- ▶ Connect the manometer to the burner pressure measuring point.

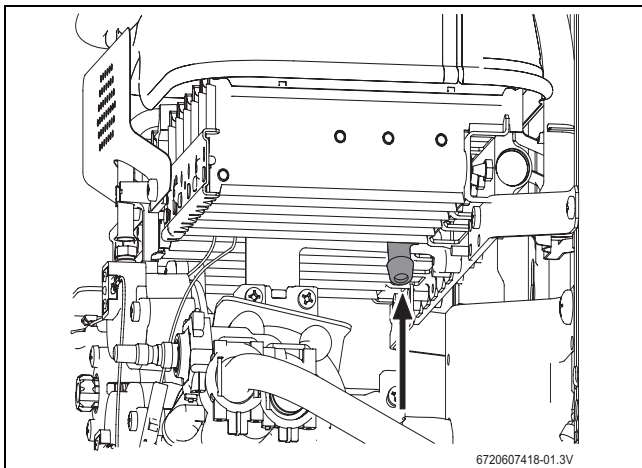

Fig. 16 Pressure measurement point

Maximum gas flow adjustment

- ▶ Remove the seal from the adjusting screw (Fig. 17).

- ▶ Turn on the heater with the gas selector set to the left (maximum position).

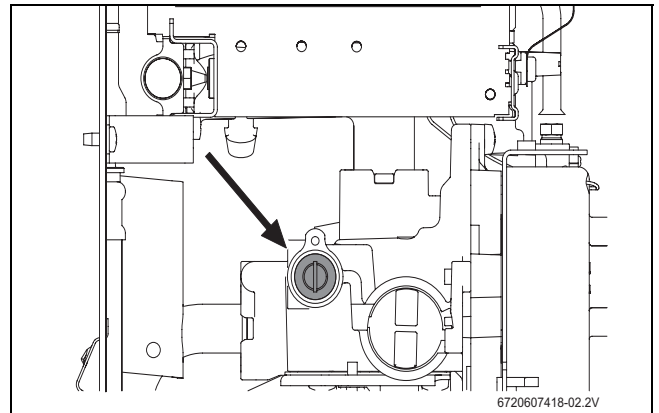

Fig. 17 Maximum gas flow adjusting screw

- ▶ Open various hot water taps.
- ▶ Using the adjusting screw (Fig. 17), regulate the gas pressure until the values indicated in the table 6 are achieved.
- ▶ Seal the adjusting screw once again.

Minimum gas flow adjustment



The minimum gas flow adjustment is performed automatically after the adjustment of the maximum gas flow.

		Natural gas H	LP gas
MAX Burner Pressure (kPa)	GWH10	0.69	2.00
	GWH13	0.66	1.90
	GWH16	0.44	2.20

Table 6 Burner pressure

6.3 Conversion to a different type of gas

Only use **original conversion parts**.

The conversion must only be performed by a qualified technician. Original conversion kits are supplied with assembly instructions.

7 Maintenance



DANGER:

Failure to perform maintenance procedures can lead to appliance malfunction, errors, service calls and loss of warranty.

To ensure that gas consumption and the environmental load (pollution, etc.) remain as negligible as possible over time, we recommend the appliance be maintained on an annual basis.

These jobs can only be done by a Bosch authorised service agent.



Maintenance must only be performed by a qualified technician. Maintenance information is contained in a service manual available to licenced technicians upon request from Bosch.

7.1 Flue gas safety device



DANGER:

The probe must never be turned off, modified or replaced with a different part under any circumstances.

Operation and precautions

This probe verifies the condition of flue gas evacuation and, in case of malfunction, it automatically turns off the heater. This prevents combustion gases from entering the room where the gas heater has been installed. The probe restarts after a reset period.

If the heater turns off during operation:

- ▶ Ventilate the room.
- ▶ After 10 minutes, turn on the heater once again.
Call a qualified technician if the same thing happens again.



DANGER:

The user must never touch the flue gas safety device.

Maintenance*

If the probe malfunctions, proceed as follows:

- ▶ Unscrew the probe fixing screw.
- ▶ Detach the ignition unit terminal.
- ▶ Replace the faulty part and re-assemble in reverse order.

Operating check*

To check the correct operation of the flue gas safety device, proceed as follows:

- ▶ Remove the combustion gases flue pipe.
- ▶ temporarily replace it with a pipe (approximately 50 cm long) blocked at one end.
- ▶ The pipe must be installed vertically.
- ▶ Turn on the heater at nominal power and with the temperature selector adjusted to maximum temperature.

In these conditions, the heater must turn off no more than two minutes afterwards, at most. Remove the pipe and replace the flue pipe.

* These procedures must be performed by a qualified installer/service agent.

8 Problems

8.1 Problem/cause/solution

Assembly, maintenance and repairs must be performed by qualified technicians only. The following chart offers solutions to possible problems.

Problem	Cause	Solution
The heater does not ignite and digital display is turned off.	Switch turned off.	Check switch position.
Slow and difficult ignition of the burner.	Reduced water flow.	Call a qualified technician.
Red LED in switch flashes.	Reduced water flow.	Call a qualified technician.
Water at low temperature.		Check the temperature selector position and adjust it according to the desired water temperature.
Water is not heated, no flame.	Insufficient gas supply. Gas Cylinders may be empty	If sufficient gas appears to be available call a qualified technician.
Digital display shows “E9”.	Temperature limiter has tripped	Wait 10 minutes and restart the heater. If the problem persists, call a qualified technician.
Digital display shows “A4”.	Flue gas safety device has tripped	Vent the area. Wait 10 minutes and restart the heater. If the problem persists, call a qualified technician.
Incorrect temperature information in the appliance digital display.	Insuficient contact of the temperature sensor.	Call a qualified technician.
Digital display shows “E1”.	Water temperature sensor has tripped (outlet water temperature above 85 °C).	Reduce the water temperature using the gas and/or temperature adjustment selector. If the problem persists, call a qualified technician.
Digital display shows “A7”.	Temperature sensor incorrectly connected.	Call a qualified technician.
	Temperature sensor defective.	Call a qualified technician.
Digital display shows “F7” or “E0”.	Blocked Heater.	Turn the heater off and on, if the problem persists, call a qualified technician.

Table 7

Problem	Cause	Solution
Digital display shows “EA”.	There is spark but the main burner does not ignite, heater blocked.No ionisation probe signal .	Check: <ul style="list-style-type: none"> • Gas supply, position of valves, empty LP gas cylinders.
Digital display shows “F0”.	Power was activated with a hot water tap running.	Turn the water off and on. If the problem persists, call a qualified technician.
Reduced water flow.	Insufficient water supply pressure.	Call a qualified technician.
	Dirty taps or mixers.	Call a qualified technician
	Gas valve blocked.	Call a qualified technician
	Heat exchanger blocked (limescale).	Call a qualified technician

Table 7

9 Environmental protection

Environmental protection is a basic company strategy of Bosch. The quality of our products, profitability and environmental protection are equal-ranking goals for us. Laws and regulations concerning environmental protection are strictly observed. We use the best possible technology and materials, under economic considerations, to protect the environment.

Packaging

We participate in the recycling program of the respective country to ensure optimal recycling. All of our packaging materials are environmental-friendly and can be recycled.

Old appliances

Old appliances contain valuable materials that should be recycled. The assemblies can be easily detached and synthetic materials are marked accordingly. The assemblies can therefore be sorted out and passed on for recycling or disposal.

10 Water quality

All Bosch water heating appliances are constructed from high quality materials and components and all are certified for compliance with relevant parts of Australian and New Zealand gas, electrical and water standards.

Whilst Bosch water heaters are warranted against defects, the warranty is conditional upon correct installation and use, in accordance with detailed instructions provided with the heater. In the case of the water supplied to the heater, it is important that the water quality be of acceptable standard.

The water quality limits/parameters listed in water quality table are considered acceptable and generally, Australian and New Zealand suburban water supplies fall within these limits/parameters.

In areas of Australia and New Zealand where water may be supplied, either fully or partly, from bores, artesian wells or similar, one or more of the important limits may well be exceeded and the heater could, therefore, be at risk of failure.

Where uncertainty exists concerning water quality, intending appliance users should seek a water analysis from the water supplying authority and in cases where it is established that the water supply does not meet the quality requirements of the water quality table, the Bosch warranty would not apply.

Water quality table

Maximum levels

pH	Saturation Index (LSI) (Langlier)	Total Hardness	Chlorides	Sodium	Iron
6.5-9.0	+0.4 to -1.0 at 65 °C	200 mg/l	250 mg/l	180 mg/l	1 mg/l

Table 8

11 Warranty details

Robert Bosch (Australia) Pty Ltd (Bosch) Manufacturer's Warranty (Applicable for purchases from 1 January 2012)

All Bosch hot water units are carefully checked, tested and subject to stringent quality controls.

1. Warranty

Bosch offers, at its option, to repair or exchange this Bosch hot water unit or the relevant part listed in clause 2 below at no charge, if it becomes faulty or defective in manufacture or materials during the warranty period also stated in clause 2. This warranty is offered in addition to any other rights or remedies held by a consumer at law.

2. Warranty periods & coverage

- (a) Domestic applications: 2 years (parts and labour)
- (b) Heat exchangers used in domestic applications: 10 years (parts only)
- (c) Commercial applications: 12 months (parts and labour)
- (d) Heat exchangers used in commercial applications: 12 months (part only)

All warranty periods commence on the date of purchase of the hot water unit by the end-user. However, where the date of purchase by the end-user is more than 24 months after the date of manufacture, all warranty periods will automatically commence 24 months after the date of manufacture.

3. Warranty exclusions

This warranty is VOID if any damage to or failure of the hot water unit is caused wholly or partly by:

- (a) faulty installation
- (b) neglect, misuse, accidental or non-accidental damage, failure to follow instructions
- (c) use of the unit for purposes other than which it was designed or approved
- (d) unauthorised repairs or alterations to the unit without Bosch's consent
- (e) use of unauthorised parts and accessories without Bosch's consent
- (f) use of non-potable water or bore water in the hot water unit (see product instructions for further details)
- (g) continued use after a fault becomes known or apparent.

This warranty DOES NOT include:

- (a) costs of consumables or accessories
- (b) wear and tear, normal or scheduled maintenance
- (c) to the extent permitted by law, any damage to property, personal injury, direct or indirect loss, consequential losses or other expenses
- (d) changes in the condition or operational qualities of the hot water unit due to incorrect storage or mounting or due to climatic, environmental or other influences.

NOTE: Any service call costs incurred by the owner or user of the hot water unit for any matter not covered by the terms of this warranty will not be reimbursed by Bosch, even if those costs are incurred during the warranty period. If the hot water unit is located outside the usual operating area of a Bosch service agent, the agent's travel, freight or similar costs are not covered by this warranty and must be paid by the owner or user of the hot water unit.

4. Warranty conditions

- (a) Proof of purchase may be required.
- (b) The hot water unit must be installed by an authorised and licensed installer.
- (c) Proof may be required of the date of installation and correct commissioning of the hot water unit has been carried out to Bosch's satisfaction (such as a certificate of compliance).
- (d) Repair or replacement of the hot water unit or any parts under this warranty does not lengthen or renew the warranty period.
- (e) This warranty is not transferable and is only offered to the original purchaser of the hot water unit.
- (f) No employee or agent of Bosch is authorised to amend the terms of this warranty.
- (g) This warranty only applies to Bosch hot water units purchased from an authorised reseller and installed in

Australia or New Zealand.

(g) To the extent that any condition or warranty implied by law is excludable, such condition or warranty is excluded.

5. How to lodge a warranty claim and warranty procedure

(a) Warranty claims must be made with the Bosch Customer Contact Centre (Australia: ph 1300 307 037; New Zealand: ph 0800 543 352). Please be ready to provide the model and serial numbers, date of installation, purchase details and a full description of the problem. Warranty claims must be made before the end of the warranty period.

(b) All warranty service calls must be conducted by an authorised Bosch service agent.

(c) Invoices for attendance and repair of a hot water unit by third parties not authorised by Bosch will not be accepted for payment by Bosch.

6. Privacy Act 1988 (Cth)

A customer's personal information collected during warranty claims may be used for the provision of customer support, for the provision of information about products and services and for other marketing activities undertaken by Bosch and its Bosch Service Agents who are authorised to carry out warranty repairs on behalf of Bosch (Purpose). Bosch is committed to protecting the privacy of its customers' personal information. It will act in compliance with the National Privacy Principles and Privacy Act 1988 (Cth). Bosch will not forward customers' personal information to third parties other than for the Purpose. A customer can object at any time to the use of their personal information for the Purpose. Bosch will cease to use a customer's personal information accordingly if an objection is made.

7. Bosch contact details

If you have any questions about this warranty or to lodge a warranty claim, please contact:

Robert Bosch (Australia) Pty Ltd
1555 Centre Road, Clayton, Victoria 3168
Tel: Australia: 1300 307 037
Tel: New Zealand: 0800 543 352

IMPORTANT NOTE FOR AUSTRALIAN CONSUMERS

Our goods come with guarantees that cannot be excluded under the Australian Consumer Law. You are entitled to a replacement or refund for a major failure and for compensation for any other reasonably foreseeable loss or damage. You are also entitled to have the goods repaired or replaced if the goods fail to be of acceptable quality and the failure does not amount to a major failure.

Notes



6720608992

Australia

Robert Bosch (Australia) Pty Ltd
1555 Centre Rd
Clayton, VIC 3168
Phone 1300 30 70 37
Fax 1300 30 70 38
www.bosch.com.au/hotwater

New Zealand

Phone 0800 4 Bosch or 08 543 352
www.bosch.co.nz