

# *Owner's Guide and Installation Instructions*



## *Gas Domestic Outdoor Water Heater 647270 models*

**everhot<sup>®</sup>**

*This water heater must be installed and serviced by a qualified person.  
Please leave this guide with the householder.*

**⚠ Warning:** Upon completion of the installation and commissioning of the water heater, leave this guide with the householder or responsible officer. **DO NOT** leave this guide inside of the cover of the water heater, as it may interfere with the safe operation of the water heater or ignite when the water heater is turned on.

---

#### **PATENTS**

This water heater may be protected by one or more patents or registered designs in the name of Rheem Australia Pty Ltd.

#### **TRADEMARKS**

® Registered trademark of Rheem Australia Pty Ltd.  
™ Trademark of Rheem Australia Pty Ltd.

**Note:** Every care has been taken to ensure the accuracy in preparation of this publication. No liability can be accepted for any consequences, which may arise as a result of its application.

---

# CONTENTS

---

**HOUSEHOLDER – We recommend you read pages 4 to 21.**

The other pages are intended for the installer  
but may be of interest.

<b>About Your Water Heater .....</b>	<b>4</b>
<b>Regular Care .....</b>	<b>10</b>
<b>Water Supplies.....</b>	<b>14</b>
<b>Save A Service Call .....</b>	<b>18</b>
<b>Installation.....</b>	<b>22</b>
<b>Connections – Plumbing .....</b>	<b>32</b>
<b>Commissioning.....</b>	<b>36</b>
<b>Lighting The Water Heater .....</b>	<b>40</b>
<b>Draining The Water Heater .....</b>	<b>44</b>
<b>Warranty .....</b>	<b>46</b>

---

# ABOUT YOUR WATER HEATER

---

## WATER HEATER APPLICATION

This water heater is designed for use in a single family domestic dwelling for the purpose of heating potable water. Its use in an application other than this may shorten its life.

## MODEL TYPE

The Everhot® water heater model you have chosen is suitable for outdoor installation only. This model is a 5 star gas water heater.

Water is stored in a vitreous enamel lined steel cylinder and heated by a gas burner located under the cylinder. The heat produced by the burner is transferred to the water through the base, top and wall of the cylinder and through the wall of a flue pipe which passes through the centre of the cylinder. The gas supply to the burner is controlled by the thermostat so the water is heated to a constant temperature.

Automatic safety controls are fitted to the water heater to provide safe and efficient operation.

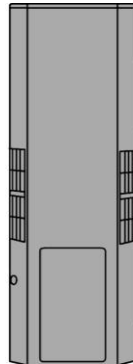

## MAINS PRESSURE

The water heater is designed to operate at mains pressure by connecting directly to the mains water supply. If the mains supply pressure in your area exceeds that **shown on page 25**, a pressure limiting valve must be fitted. The supply pressure should be greater than 350 kPa for true mains pressure operation to be achieved.

**HOW HOT SHOULD THE WATER BE?**

The water heater features a user adjustable thermostat, which allows you to personally choose the most suitable temperature for your hot water needs. Refer to “**Temperature Adjustment**” on page 5.

To meet the requirements of the National Plumbing Standard the temperature of the stored water must not be below 60°C.

**Note:** AS 3498 requires that a water heater provides the means to inhibit the growth of Legionella bacteria in potable water. This water heater can satisfy this AS 3498 requirement provided it is operating and the thermostat setting is 60°C or higher, including when it is used as an in-series booster water heater for a solar water heater.

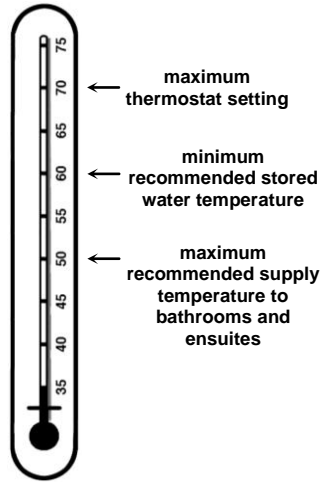

**HOTTER WATER INCREASES THE RISK OF SCALD INJURY**

This water heater can deliver water at temperatures which can cause scalding. Check the water temperature before use, such as when entering a shower or filling a bath or basin, to ensure it is suitable for the application and will not cause scald injury.

We recommend and it may also be required by regulations that an approved temperature limiting device be fitted into the hot water pipe work to the bathroom and ensuite when an Everhot water heater is installed. This will keep the water temperature below 50°C at the bathroom and ensuite. The risk of scald injury will be reduced and still allow hotter water to the kitchen and laundry.

**TEMPERATURE ADJUSTMENT**

The temperature adjusting dial is on the gas valve, located behind the access cover on the lower front of the water heater. A setting of ‘4’ will normally maintain the water temperature at about 60°C. Each number represents a temperature difference of approximately 10°C.

To increase the water temperature to 70°C, turn the temperature adjusting dial anticlockwise to a setting of ‘5’. Refer to “**Hotter Water Increases the Risk of Scald Injury**” on page 5.

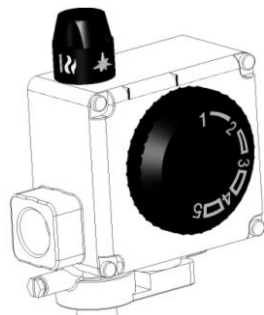

**⚠ WARNING**

This water heater is only intended to be operated by persons who have the experience or the knowledge and the capabilities to do so. This water heater is not intended to be operated by persons with reduced physical, sensory or mental capabilities i.e. the infirm, or by children. Children should be supervised to ensure they do not interfere with the water heater.

**SAFETY**

This water heater is supplied with a thermostat, an over-temperature cut-out, a thermocouple and a combination temperature pressure relief valve. These devices must not be tampered with or removed. The water heater must not be operated unless these devices are fitted and are in working order.

**⚠ Warning:** For continued safety of this water heater it must be installed, operated and maintained in accordance with the Owner's Guide and Installation Instructions.

**The Everhot warranty may not cover faults if relief valves or other safety devices are tampered with or if the installation is not in accordance with these instructions.**

- Do not store **flammable or combustible materials** near the water heater. Flammable liquids (such as petrol), newspapers and similar articles must be kept well away from the water heater and the flue terminal.
- Do not use **aerosols, stain removers and household chemicals** near the water heater whilst it is working. Gases from some aerosol sprays, stain removers and household chemicals become corrosive when drawn into a flame.
- Do not store **swimming pool chemicals, household cleaners**, etc., near the water heater.
- Do not place anything on top of the water heater or in contact with the flue terminal. Ensure the flue terminal is not obstructed in any way at any time.
- Do not use Propane / Butane gas mixtures in a Propane model. A Propane model is designed to operate on Propane only. The use of Propane / Butane mixture, such as automotive LPG fuel, in a Propane model is unsafe and can cause damage to the water heater.



### PIEZO IGNITION

The “Piezo” push button igniter makes lighting the pilot flame of your water heater very easy. Simply follow the instructions on the label attached to the back of the access door. There is no need for matches to light the water heater.

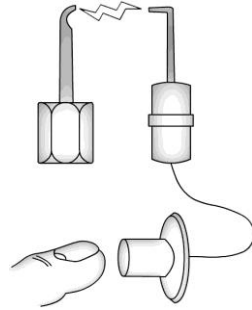

### PILOT IGNITER

A permanent pilot flame burns to ignite the main burner automatically. Heat from the pilot is absorbed by the water.

### PRECAUTIONS

Where damage to property can occur in the event of the water heater leaking, the water heater must be installed in a safe tray. Construction, installation and draining of a safe tray must comply with AS/NZS 3500.4 and all local codes and regulatory authority requirements.

The water heater must be maintained in accordance with the Owner's Guide and Installation Instructions. Refer to “[Regular Care](#)” on page 10 and to “[Anode Inspection and Replacement](#)” on page 15.

If this water heater is to be used where an uninterrupted hot water supply is necessary for your application or business you should ensure that you have back up redundancy within the hot water system design. This should ensure the continuity of hot water supply in the event that this water heater were to become inoperable for any reason. We recommend you seek advice from your plumber or specifier about your needs and building back up redundancy into your hot water supply system.

### TO TURN OFF THE WATER HEATER

If it is necessary to turn off the water heater:

- Shut down the gas control (refer to “[Close Down Procedure](#)” on page 43).
- Close the gas isolation valve at the inlet to the gas control.
- Close the cold water isolation valve at the inlet to the water heater.

### TO TURN ON THE WATER HEATER

- Open the cold water isolation valve fully at the inlet to the water heater.
- Open the gas isolation valve fully at the inlet to the gas control.
- Light the water heater (refer to “[Lighting the Water Heater](#)” on page 40).

## **GOING ON HOLIDAYS**

If you plan to be away from home for one or two nights, we suggest you leave the water heater switched on. However, if you plan to stay away more than a few nights, the gas knob can be set to the red star “★” (pilot) position (facing the front) to conserve energy (refer to steps 1, 2 and 4 of “[Close Down Procedure](#)” on page 43).

If it is necessary to turn off the water heater, refer to “[To Turn Off The Water Heater](#)” on page 7.

**Note:** When turned back on from the red star “★” (pilot) position or white dot “●” (off) position, the water heater may take up to an hour to reheat if the water has lost temperature.

## **HOW DO I KNOW IF THE WATER HEATER IS INSTALLED CORRECTLY?**

Installation requirements are shown on [pages 22 to 30](#). The water heater must be installed:

- by a qualified person, and
- in accordance with the installation instructions, and
- in compliance with Standards AS/NZS 3500.4, AS 5601 or AS/NZS 5601.1, as applicable under local regulations, and all local codes and regulatory authority requirements.

In New Zealand, the installation must also conform with NZS 5261, as applicable under local regulations, and the New Zealand Building Code.

## **VICTORIAN CUSTOMERS**

Notice to Victorian Customers from the Victorian Plumbing Industry Commission. This water heater must be installed by a licensed person as required by the Victorian Building Act 1993.

Only a licensed person will give you a Compliance Certificate, showing that the work complies with all the relevant Standards. Only a licensed person will have insurance protecting their workmanship for 6 years. Make sure you use a licensed person to install this water heater and ask for your Compliance Certificate.

## **DOES THE WATER CHEMISTRY AFFECT THE WATER HEATER?**

The water heater is suitable for most public water supplies, however some water chemistries may have detrimental effects on the water heater, its components and fittings. Refer to “[Water Supplies](#)” on page 14.

If you are in a known harsh water area or you are not sure of your water chemistry, have your water checked against the conditions [described on pages 14 to 17](#).



### **HOW LONG WILL THE WATER HEATER LAST?**

The water heater is supported by a manufacturer's warranty (refer to page 46). There are a number of factors that will affect the length of service the water heater will provide. These include but are not limited to the water chemistry, the water pressure, the water temperature (inlet and outlet) and the water usage pattern. Refer to "Precautions" on page 7.

---

## REGULAR CARE

---

### ANNUAL SERVICE

For safe and efficient operation, it is recommended an annual service be conducted on the water heater.

**⚠ Warning:** Servicing of a water heater must only be carried out by qualified personnel. Phone Rheem Service or their nearest Accredited Service Agent.

**Note:** The annual service and routine replacement of any components, if required, are not included in the Everhot warranty. A charge will be made for this work. Only genuine replacement parts should be used on this water heater.

The annual service includes the following actions:

- Inspect and flush the temperature pressure relief valve.
- Inspect and flush the expansion control valve (if fitted).
- Check and if necessary adjust the gas pressure.
- Check the piezo igniter, gas control and thermocouple.
- Check the operation of and clean the pilot light and main burner.
- Visually check the unit for any potential problems.
- Inspect all connections.
- Check the drain line from the safe tray (if one is installed) is not blocked.

**Note:** The water heater may need to be drained during this service. After the completion of the service, the water heater will take some time to reheat the water. Hot water may not be available for a while.

**MAJOR FIVE YEAR SERVICE**

It is recommended a major five year service be conducted on the water heater.

**⚠ Warning:** Servicing of a water heater must only be carried out by qualified personnel. Phone Rheem Service or their nearest Accredited Service Agent.

**Note:** The five year service and routine replacement of any components, such as the anode and relief valve(s), are not included in the Everhot warranty. A charge will be made for this work. Only genuine replacement parts should be used on this water heater.

The major service includes the following actions:

- Replace the temperature pressure relief valve.
- Inspect and flush the expansion control valve (if fitted). If required, replace the valve.
- Inspect and if required, replace the anode.

If the anode is not replaced, it should be replaced within three years of this service (refer to **"Anode Inspection and Replacement"** on page 15).

- Check and if necessary adjust the gas pressure.
- Check the piezo igniter, gas control and thermocouple.
- Check the operation of and clean the pilot light and main burner.
- Visually check the unit for any potential problems.
- Inspect all connections.
- Check the drain line from the safe tray (if one is installed) is not blocked.

**Note:** The water heater may need to be drained during this service. After the completion of the service, the water heater will take some time to reheat the water. Hot water may not be available for a while.

### MINOR SIX MONTH MAINTENANCE

It is recommended minor maintenance be performed every six months by the dwelling occupant.

The minor maintenance includes:

- Operate the easing lever on the temperature pressure relief valve. It is very important you raise and lower the lever gently. Refer to “**Temperature Pressure Relief Valve**” on page 13.

 **Warning:** Exercise care to avoid any splashing of water, as water discharged from the drain line will be hot. Stand clear of the drain line's point of discharge when operating the valve's lever.

- Operate the easing lever on the expansion control valve (if fitted). It is very important you raise and lower the lever gently. Refer to “**Expansion Control Valve**” on page 12.
- Check the drain line from the safe tray (if one is installed) is not blocked.

### EXPANSION CONTROL VALVE

In many areas, including South Australia, Western Australia and scaling water areas, an expansion control valve is fitted to the cold water line to the water heater. The expansion control valve may discharge a small quantity of water from its drain line during the heating period instead of the temperature pressure relief valve on the water heater.

Operate the easing lever on the expansion control valve once every six months. **It is very important you raise and lower the lever gently.** The expansion control valve should be checked for performance or replaced at intervals not exceeding 5 years, or more frequently in areas where there is a high incidence of water deposits.

## TEMPERATURE PRESSURE RELIEF VALVE

This valve is near the top of the water heater and is essential for its safe operation. It is possible for the valve to release a little water through the drain line during each heating period. This occurs as the water is heated and expands by approximately 1/50 of its volume.

Continuous leakage of water from the valve and its drain line may indicate a problem with the water heater (refer to “[Temperature Pressure Relief Valve Running](#)” on page 19).

**⚠ Warning:** Never block the outlet of this valve or its drain line for any reason.

Operate the easing lever on the temperature pressure relief valve once every six months. **It is very important you raise and lower the lever gently.**

**⚠ Warning:** Failure to do this may result in the water heater cylinder failing.

**⚠ Warning:** Exercise care to avoid any splashing of water, as water discharged from the drain line will be hot. Stand clear of the drain line’s point of discharge when operating the valve’s lever.

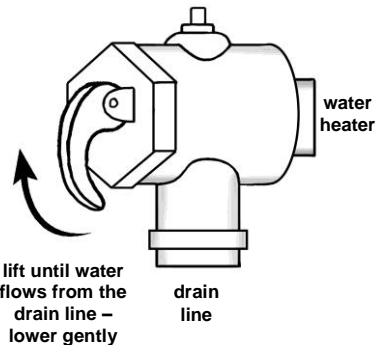
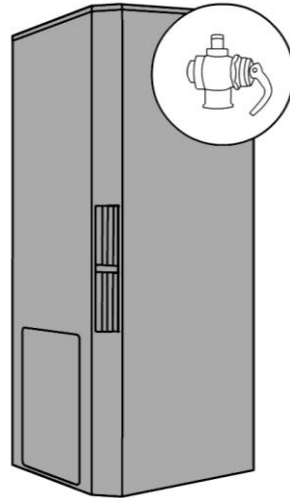

If water does not flow freely from the drain line when the lever is lifted, then the water heater must be checked. Phone Rheem Service or their nearest Accredited Service Agent to arrange for an inspection.

The temperature pressure relief valve should be replaced at intervals not exceeding 5 years, or more frequently in areas where there is a high incidence of water deposits (refer to “[Water Supplies](#)” on page 14).

---

## WATER SUPPLIES

---

**This water heater must be installed in accordance with this advice to be covered by the Everhot warranty.**

This water heater is manufactured to suit the water conditions of most public reticulated water supplies. However, there are some known water chemistries which can have detrimental effects on the water heater and its operation and / or life expectancy. If you are unsure of your water chemistry, you may be able to obtain information from your local water supply authority. This water heater should only be connected to a water supply which complies with these guidelines for the Everhot warranty to apply.

### ANODE

The vitreous enamel lined cylinder of the water heater is only covered by the Everhot warranty when the total dissolved solids (TDS) content in the water is less than 600 mg/L and when the correct colour coded anode is used. If an incorrect colour coded anode is used in the water heater, any resultant faults will not be covered by the Everhot warranty. In addition, the use of an incorrect colour coded anode may shorten the life of the water heater cylinder.

The correct colour coded anode must be selected and fitted to the water heater in accordance with the following advice and the [Anode Selection chart](#) on page 15 for the Everhot warranty to apply to the water heater cylinder.

Total Dissolved Solids	Anode colour code
0 – 40 mg/L	Green
40 – 150 mg/L	Green or Black
150 – 400 mg/L	Black
400 – 600 mg/L	Black or Blue
600 mg/L + *	Blue (no cylinder warranty)

\* **Note:** The Everhot warranty does not apply to the cylinder if the water heater is connected at any time to a water supply where the TDS content of the water exceeds 600 mg/L.

The changing of an anode must be carried out by a qualified person.

**Note:** Some water analysis reports may state the conductivity of the water rather than the level of total dissolved solids. Conductivity, measured in microsiemens per centimetre ( $\mu\text{S} / \text{cm}$ ), is directly proportional to the TDS content of the water. TDS, in mg / L, is approximately 70% of the conductivity in  $\mu\text{S} / \text{cm}$ .

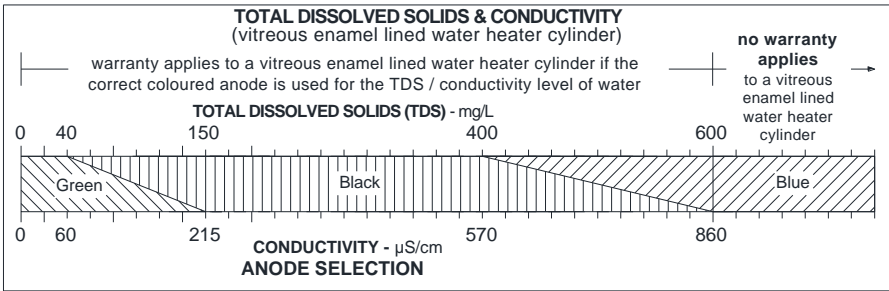

## ANODE INSPECTION AND REPLACEMENT

The anodes installed in a vitreous enamel lined steel water heater cylinder will slowly dissipate whilst protecting the cylinder. The life of the cylinder may be extended by replacing the anodes.

If the anodes are not replaced during a five year service (refer to “Major Five Year Service” on page 11) then the maximum time after installation when the anodes should be replaced for this gas water heater is 8 years.

For water supplies which are either softened, desalinated or where the water supply may alternate between a water tank and a reticulated public supply or another supply, it is recommended the anodes be replaced within 5 years of installation.

## CAUTION

If the water supply has a TDS greater than 150 mg/L and a green anode has not been changed to a black anode, or if the TDS is greater than 600 mg/L and the anode has not been changed to a blue anode, there is the possibility the anode may become overactive and hydrogen gas could accumulate in the top of the water heater during long periods of no use. In areas where this is likely to occur, the installer should instruct the householder on how to dissipate the gas safely.

If, under these conditions, the water heater has not been used for two or more weeks the following procedure should be carried out before using any electrical appliances (automatic washing machines and dishwashers) which are connected to the hot water supply.

The hydrogen, which is highly flammable, should be vented safely by opening a hot tap and allowing the water to flow. There should be no smoking or naked flame near the tap whilst it is turned on. Any hydrogen gas will be dissipated. This is indicated by an unusual spurting of the water from the tap. Once the water runs freely, any hydrogen in the system will have been released.

**SATURATION INDEX**

The saturation index (SI) is used as a measure of the water’s corrosive or scaling properties.

In a corrosive water supply, the water can attack copper parts and cause them to fail.

In a scaling water supply calcium carbonate is deposited out of the water onto any hot metallic surface.

Where the saturation index exceeds +0.40, the water is very scaling. An expansion control valve must be fitted on the cold water line after the non-return valve to protect and for the Everhot warranty to apply to the temperature pressure relief valve and water heater cylinder.

Water which is scaling may be treated with a water softening device to reduce the saturation index of the water.

Refer to the **Saturation Index chart** on page 16.

Refer to the **cold water connection detail** on page 32 for the position of the expansion control valve.

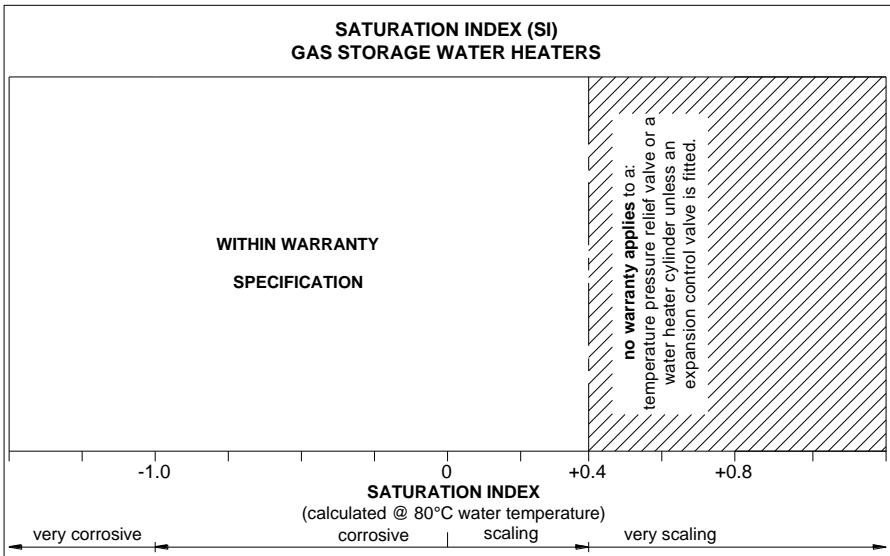



**CHANGE OF WATER SUPPLY**

The changing or alternating from one water supply to another can have a detrimental effect on the operation and / or life expectation of a water heater cylinder and a temperature pressure relief valve.

Where there is a changeover from one water supply to another, e.g. a rainwater tank supply, bore water supply, desalinated water supply, public reticulated water supply or water brought in from another supply, then water chemistry information should be sought from the supplier or it should be tested to ensure the water supply meets the requirements given in these guidelines for the Everhot warranty to apply.

**SUMMARY OF WATER CHEMISTRY ADVICE AFFECTING WARRANTY**

The water heater and its components are not suitable for certain water chemistries. Those chemistries are listed below. If the water heater is connected at any time to a water supply with the following water chemistry, the Everhot warranty will not cover any resultant faults on the components listed below:

<b>Water Chemistry</b>	<b>Component</b>
Total Dissolved Solids (TDS) > 600 mg/L	water heater cylinder
Total Dissolved Solids (TDS) not suitable for anode type	water heater cylinder
Saturation Index (SI) > +0.4 (if expansion control valve is not fitted)	water heater cylinder temperature pressure relief valve

---

## SAVE A SERVICE CALL

---

Check the items below before making a service call. You will be charged for attending to any condition or fault that is not related to manufacture or failure of a part.

### NOT ENOUGH HOT WATER (OR NO HOT WATER)

- **Are you using more hot water than you think?**

Is one outlet (especially the shower) using more hot water than you think?

Very often it is not realised the amount of hot water used, particularly when showering. Carefully review the family's hot water usage.

Have your plumber fit a flow control valve to each shower outlet to reduce water usage.



- **Pilot flame alight?**

Check the pilot flame is burning by removing the access cover.

Relight the pilot flame according to the lighting instructions (refer to "[Lighting the Water Heater](#)" on page 40).

- **Temperature pressure relief valve running**

Is the relief valve discharging too much water?

Refer to "[Temperature Pressure Relief Valve Running](#)" on page 19.

- **Thermostat setting**

Ensure the thermostat setting is appropriate.

You may choose to adjust the thermostat upwards to gain additional hot water capacity.

**⚠ Warning:** Hotter water increases the risk of scald injury.

- **Water heater size**

Do you have the correct size water heater for your requirements?

The sizing guide in the sales literature suggests average sizes that may be needed.

### WATER NOT HOT ENOUGH

You may find that due to heavy hot water usage the water temperature may be lower than normally expected.

---

## TEMPERATURE PRESSURE RELIEF VALVE RUNNING

- **Normal Operation**

It is normal and desirable this valve allows a small quantity of water to escape during the heating cycle. However, if it discharges more than a bucket full of water in 24 hours, there may be another problem.

- **Continuous dribble**

Try gently raising the easing lever on the relief valve for a few seconds (refer to “**Temperature Pressure Relief Valve**” on page 13). This may dislodge a small particle of foreign matter and clear the fault. Release the lever gently.

- **Steady flows for long period (often at night)**

This may indicate the mains water pressure sometimes rises above the designed pressure of the water heater. Ask your installing plumber to fit a pressure limiting valve.

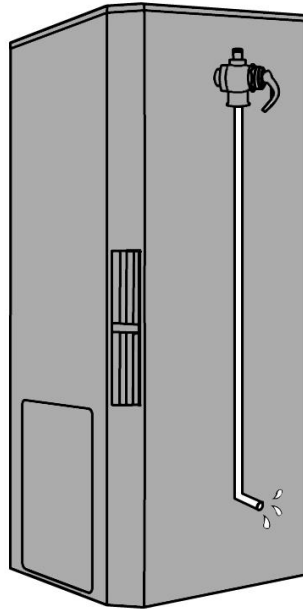

**⚠ Warning:** Never replace the relief valve with one of a higher pressure rating.

- **Heavy flows of hot water until the water heater is cold - then stops until water reheats**

The gas control **must** be turned off using the gas knob on top of the gas control thermostat (refer to “**Close Down Procedure**” on page 43). Phone Rheem Service or their nearest Accredited Service Agent to arrange for inspection.

## EXPANSION CONTROL VALVE RUNNING

If an expansion control valve is fitted in the cold water line to the water heater (refer to page 32) it may discharge a small quantity of water instead of the temperature pressure relief valve on the water heater. The benefit is that energy is conserved as the discharged water is cooler.

### CAN'T LIGHT THE PILOT FLAME

- **Is there gas to the water heater?**  
Check the gas isolation valve on the gas supply line is open.
- **Is there a normal gas supply to the rest of the premises?**  
Try lighting another gas appliance to check. If there is no gas, call the gas supplier.

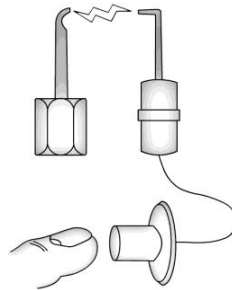

### WATER HEATER APPEARS TO BE LEAKING

When the water heater is first lit, or after a large usage of hot water, condensation may form on and drip from the burner and grille at the front of the water heater. During periods of heavy condensation, the condensate may also form around the base of the water heater. This is quite normal, especially in winter months and will dry off as the water is heated.

The water heater will drip water during the heating cycle. It is possible for several litres a day of condensation to discharge from the flue onto the burner tray especially in cool conditions. This water is not from the mains supply but is condensation from the atmosphere caused by the efficient operation of the water heater.

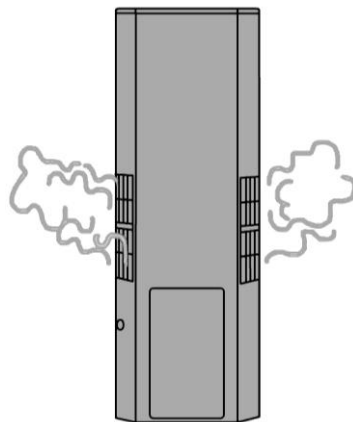

**Note:** During the heating cycle it is not unusual to see water vapour clouds steaming from the flue terminal. This is normal operation of the water heater.

**HIGHER THAN EXPECTED GAS BILLS**

Should you at any time, feel your gas account is higher than expected, we suggest you check the following points:

- Is the relief valve running excessively?

Refer to “**Temperature Pressure Relief Valve Running**” on page 19.

- Is one outlet (especially the shower) using more hot water than you think?

Refer to “**Not Enough Hot Water**” on page 18.

- Is there a leaking hot water pipe, dripping hot water tap, etc?

Even a small leak will waste a surprising quantity of hot water and gas. Replace faulty tap washers, and have your plumber rectify any leaking pipe work.

- Has there been an increase in hot water usage?

An increase in hot water usage will result in an increase in water heater operation.

- Has your water heating tariff rate been increased by your gas retailer since your previous account?



**IF YOU HAVE CHECKED ALL THE FOREGOING AND STILL BELIEVE YOU NEED ASSISTANCE, PHONE RHEEM SERVICE OR THEIR NEAREST ACCREDITED SERVICE AGENT.**

---

# INSTALLATION

---

**THIS WATER HEATER IS FOR OUTDOOR INSTALLATION ONLY.  
THIS WATER HEATER IS NOT SUITABLE FOR POOL HEATING.  
Check the water heater is suitable for the gas type available  
(refer to the rating label on the water heater).**

## **INSTALLATION STANDARDS**

The water heater must be installed:

- by a qualified person, and
- in accordance with the installation instructions, and
- in compliance with Standards AS/NZS 3500.4, AS 5601 or AS/NZS 5601.1, as applicable under local regulations, and all local codes and regulatory authority requirements.

In New Zealand, the installation must also conform with NZS 5261, as applicable under local regulations, and the New Zealand Building Code.

All packaging materials must be removed from the water heater prior to its installation. This includes the removal of the cardboard base of the carton from the underside of the water heater.

## **WATER HEATER APPLICATION**

This water heater is designed for use in a single family domestic dwelling for the purpose of heating potable water. Its use in an application other than this may shorten its life.

If this water heater is to be used where an uninterrupted hot water supply is necessary for the application or business, then there should be redundancy within the hot water system design. This should ensure the continuity of hot water supply in the event that this water heater was to become inoperable for any reason. We recommend you provide advice to the system owner about their needs and building backup redundancy into the hot water supply system.

**Note:** AS 3498 requires that a water heater provides the means to inhibit the growth of Legionella bacteria in potable water. This water heater can satisfy this AS 3498 requirement provided it is operating and the thermostat setting is 60°C or higher, including when it is used as an in-series booster water heater for a solar water heater.

## WATER HEATER LOCATION

The water heater should be installed close to the most frequently used outlet and its position chosen with safety and service in mind. Make sure people (particularly children) will not touch the flue outlet. The flue terminal must be clear of obstructions and shrubbery.

Clearance must be allowed for servicing of the water heater. The water heater must be accessible without the use of a ladder or scaffold. Make sure the temperature pressure relief valve lever is accessible and the access cover and burner can be removed for service.

If possible leave headroom of one water heater height so the anode can be inspected or replaced. Remember you may have to remove the entire water heater later for servicing.

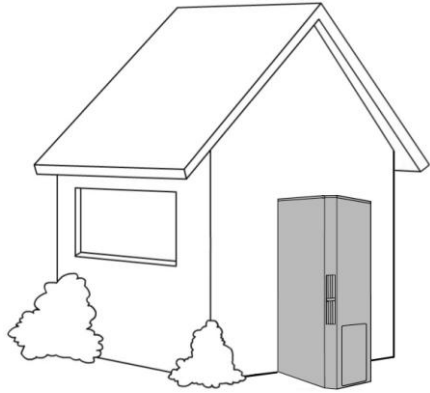

The water heater is to be installed at ground level on a concrete or brick plinth or other fireproof base as approved by the local authority. The water heater must also stand vertically upright with the back of the water heater **against or within 25 mm of an external wall**. Failure to observe this precaution can cause problems in high wind areas. A secondary flue is not required.

It is a requirement of AS 5601 and AS/NZS 5601.1 to secure the water heater to the wall. The top of the unit is to be secured to the wall using the wall bracket and masonry anchor provided, or other suitable fastener. Refer to “**Wall Bracket**” on page 25

The water heater must not be installed in an area with a corrosive atmosphere where chemicals are stored or where aerosol propellants are released. Remember the air may be safe to breathe, but when it goes through a flame, chemical changes take place which may attack the water heater.

The water heater must be located to ensure that the location of the flue terminal complies with the requirements of AS 5601 or AS/NZS 5601.1, as applicable under local regulations. As a guide the following requirements are extracted from the Gas Installations Standard. The distances are measured along the wall behind the water heater.

- At least 500 mm between the flue terminal and the edge of any opening into the building, such as an openable door or window, measured horizontally\* and vertically.
- At least 500 mm between the flue terminal and a return wall or external corner, measured horizontally\*.
- At least 500 mm from of any combustibles.

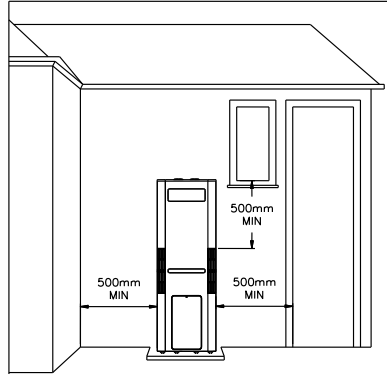

**Note:** \* If these horizontal distances cannot be achieved, AS/NZS 5601.1 states an equivalent horizontal distance measured diagonally from the nearest discharge point of the flue terminal to the opening may be deemed to comply. Check with the local regulator.

### SAFE TRAY

Where damage to property can occur in the event of the water heater leaking, the water heater must be installed in a safe tray. Construction, installation and draining of a safe tray must comply with AS/NZS 3500.4 and all local codes and regulatory authority requirements.



## WALL BRACKET

It is a requirement of AS 5601 and AS/NZS 5601.1 to secure the water heater to the wall. The top of the unit is to be secured to the wall using the wall bracket and M6.5 masonry anchor provided, or other suitable fastener.

**Note:** It is necessary to fix the bracket to the wall prior to making the water and gas connections to the water heater.

To fit the wall bracket:

- Slide the wall bracket into the formed slot at the top rear of the water heater.
- Ensure the angled profile is facing the wall.
- Mark the wall where the hole is to be drilled.
- Remove the bracket.
- Drill the hole to receive the M6.5 masonry anchor or other suitable fastener.
- Replace the wall bracket with the angled profile facing the wall.
- Secure the wall bracket to the wall.

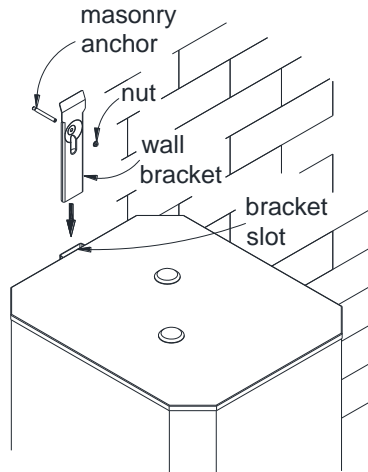

## MAINS WATER SUPPLY

Where the mains water supply pressure exceeds that shown in the table below, an approved pressure limiting valve is required and should be fitted as shown in the installation diagram (refer to diagram on page 32).

Model	270
Relief valve setting	1400 kPa
Expansion control valve setting *	1200 kPa
Max. mains supply pressure	
With expansion control valve	960 kPa
Without expansion control valve	1120 kPa

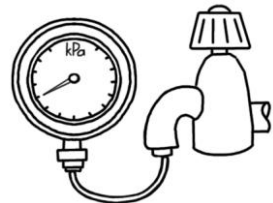

\* Expansion control valve not supplied with the water heater.

**TANK WATER SUPPLY**

If the water heater is supplied with water from a tank supply and a pressure pump system is not installed, then the bottom of the supply tank must be at least 1 m above the highest point of the hot water plumbing system, including the water heater. Care must be taken to avoid air locks. The cold water line to the water heater should be adequately sized and fitted with a full flow gate valve or ball valve.

**HOT WATER DELIVERY**

This water heater can deliver water at temperatures which can cause scalding.

It is necessary and we recommend that a temperature limiting device be fitted between the water heater and the hot water outlets in any ablation and public areas such as a bathroom, ensuite or public amenities, to reduce the risk of scalding. The installing plumber may have a legal obligation to ensure the installation of this water heater meets the delivery water temperature requirements of AS/NZS 3500.4 so that scalding water temperatures are not delivered to a bathroom, ensuite or other ablation or public area.

Where a temperature limiting device is installed adjacent to the water heater, the cold water line to the temperature limiting device can be branched off the cold water line either before or after the isolation valve, pressure limiting valve and non return valve to the water heater. If an expansion control valve is required, it must always be installed after the non return valve and be the last valve prior to the water heater.

If a pressure limiting valve is installed on the cold water line to the water heater and the cold water line to a temperature limiting device branches off before this valve or from another cold water line in the premises, then a pressure limiting valve of an equal pressure setting may be required prior to the temperature limiting device.

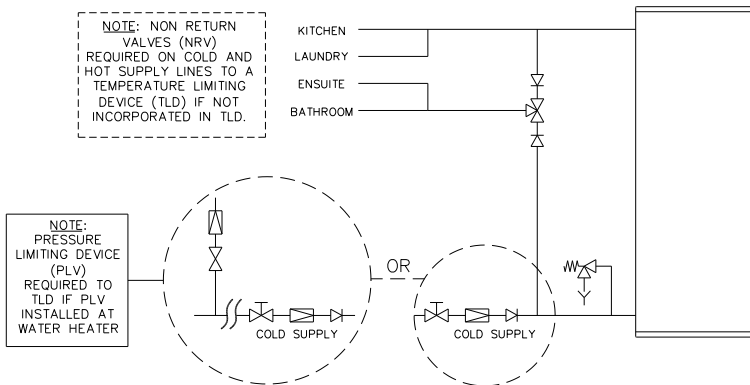

**Two Temperature Zones Using a Temperature Limiting Device**

## CIRCULATED HOT WATER FLOW AND RETURN SYSTEM

If an Everhot water heater is to be installed as part of a circulated hot water flow and return system, a storage water heater able to provide a hot water outlet temperature of at least 60°C must be used. **Note:** The thermostat must always be set to at least 60°C. Refer to the [diagram on page 27](#).

### Temperature Limiting Device

A temperature limiting device cannot be installed in circulated hot water flow and return pipe work. The tempered water from a temperature limiting device cannot be circulated. Where a circulated hot water flow and return system is required in a building, a temperature limiting device can only be installed on a dead leg, branching off the circulated hot water flow and return pipe.

If circulated tempered water were to be returned back to the water heater, depending on the location of the return line connection on the water supply line to the water heater, then either:

- water will be supplied to the cold water inlet of the temperature limiting device at a temperature exceeding the maximum recommended water supply temperature, or
- when the hot taps are closed no water will be supplied to the cold water inlet of the temperature limiting device whilst hot water will continue to be supplied to the hot water inlet of the temperature limiting device.

These conditions may result in either water at a temperature exceeding the requirements of AS/NZS 3500.4 being delivered to the hot water outlets in the ablation areas, or the device closing completely and not delivering water at all, or the device failing. Under either condition, the operation and performance of the device cannot be guaranteed.

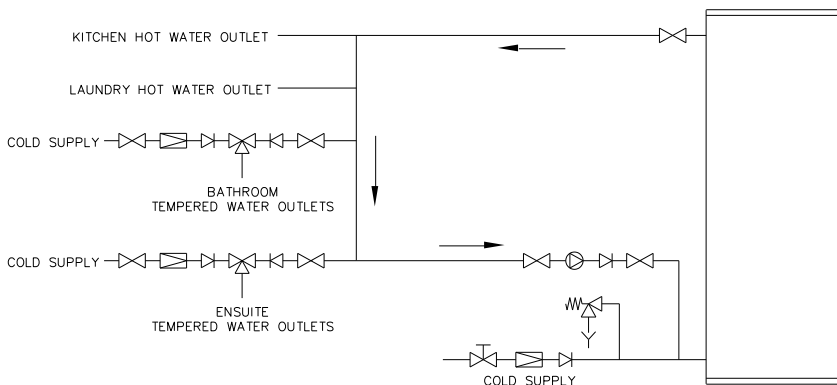

**Circulated Hot Water Flow and Return System – Gas Water Heater**

**REDUCING HEAT LOSSES**

The cold water line to and the hot water line from the water heater must be insulated in accordance with the requirements of AS/NZS 3500.4. The insulation must be weatherproof and UV resistant if exposed.

**ANODE**

The vitreous enamel lined cylinder of the water heater is covered by the Everhot warranty when the total dissolved solids (TDS) content in the water is less than 600 mg/L and when the correct colour coded anode is used. If an incorrect colour coded anode is used in the water heater, any resultant faults will not be covered by the Everhot warranty. In addition, the use of an incorrect colour coded anode may shorten the life of the water heater cylinder.

The correct colour coded anode for the water supply being used must be selected and fitted to the water heater for the Everhot warranty to apply to the water heater cylinder (refer to “Water Supplies” on page 14 and the Anode Selection chart on page 15). The black anode is typically fitted as standard.

Total Dissolved Solids	Anode colour code
0 – 40 mg/L	Green
40 – 150 mg/L	Green or Black
150 – 400 mg/L	Black
400 – 600 mg/L	Black or Blue
600 mg/L + *	Blue (no cylinder warranty)

\* **Note:** The Everhot warranty does not apply to the cylinder if the water heater is connected at any time to a water supply where the TDS content of the water exceeds 600 mg/L.

If the water supply has a TDS greater than 150 mg/L and a green anode has not been changed to a black anode, or if the TDS is greater than 600 mg/L and the anode has not been changed to a blue anode, there is the possibility the anode may become overactive and hydrogen gas could accumulate in the top of the water heater during long periods of no use. In areas where this is likely to occur, the installer should instruct the householder on how to dissipate the gas safely (refer to “Caution” on page 15).

**SADDLING - PIPE WORK**

To prevent damage to the cylinder, it is not permissible to drill through the jacket of the water heater, other than when attaching a Flashing Kit. Drilling through the jacket will void the Everhot warranty.

When attaching a Flashing Kit to the water heater jacket, we recommend the use of self-drilling screws with a maximum length of 12 mm. An effective seal must be achieved where the screw penetrates the jacket. The Flashing Kit must not be installed within a 100 mm wide vertical strip either side of the cold water inlet, hot water outlet and temperature pressure relief valve.

**Note: If the cylinder is damaged as a result of installing a Flashing Kit to the jacket, any resultant faults will not be covered by the Everhot warranty.**

**TYPICAL INSTALLATION – OUTDOOR LOCATION**

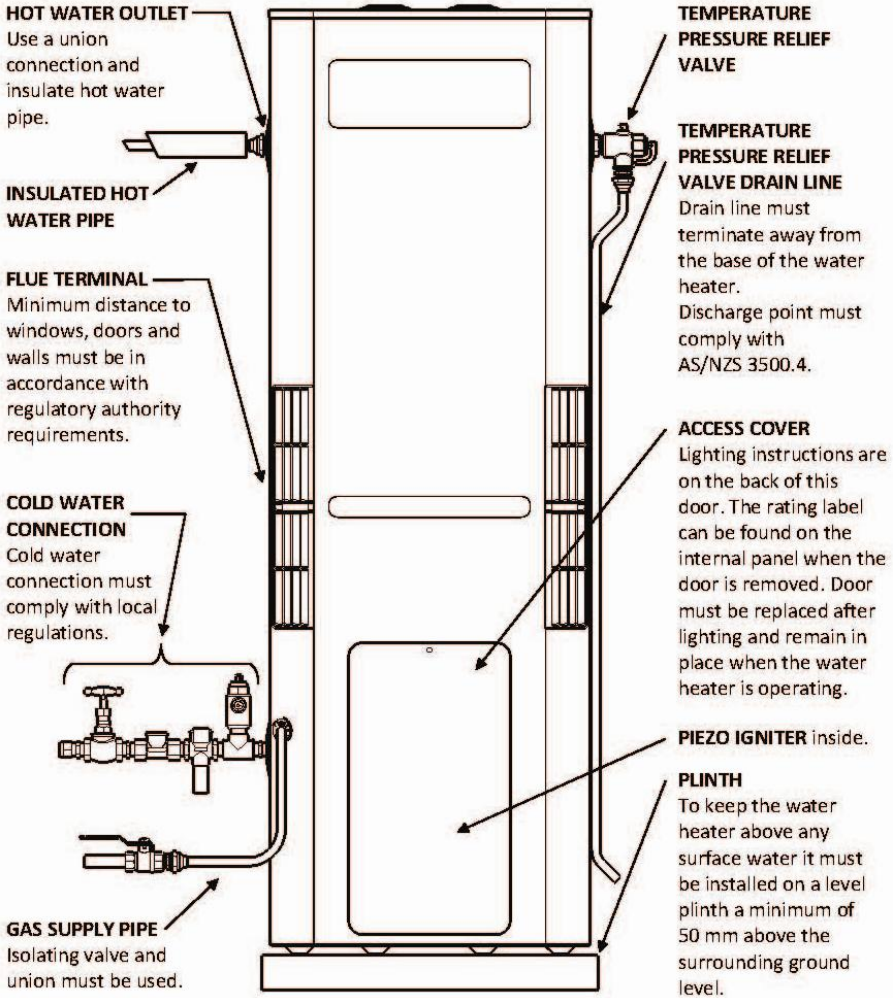

**DIMENSIONS AND TECHNICAL DATA**

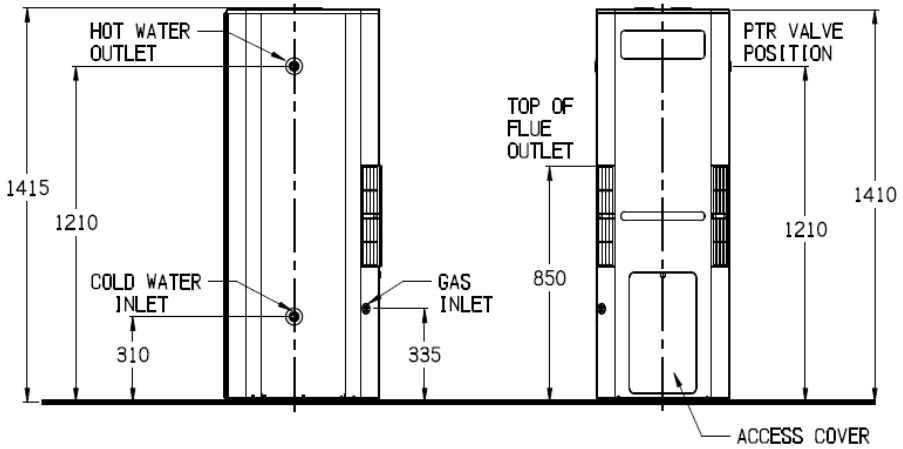
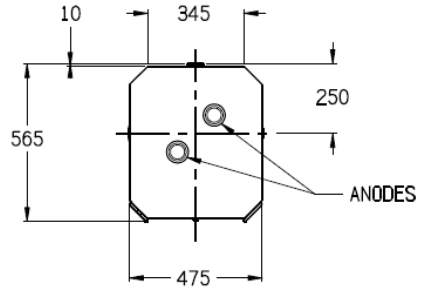

<b>Model</b>		647270
<b>Storage capacity</b>	litres	135
<b>Hourly recovery</b> (natural gas @ 45°C rise)	litres	135
<b>First Hour Capacity</b>	litres	270
<b>Mass</b>	Empty	kg 65
	Full	kg 200

<b>Gas Details</b>	Hourly Gas Consumption (MJ)	Min. Gas Supply Pressure (kPa)	Test Point Gas Pressure (kPa)	Max. Gas Supply Pressure (kPa)
Natural	30	1.13	1.00	3.50
Propane	30	2.75	2.70	3.50

Model numbers: N = Natural, P = Propane. Letters N or P is included in the model number, e.g. 647270N0, 647270P0 to denote gas type.

Technical data is subject to change.

---

# CONNECTIONS – PLUMBING

---

All plumbing work must be carried out by a qualified person and in compliance with the Standard AS/NZS 3500.4 and all local codes and regulatory authority requirements.

All gas work must be carried out by a qualified person and in compliance with the Standard AS 5601 or AS/NZS 5601.1, as applicable under local regulations, and all local codes and regulatory authority requirements. In New Zealand, the installation must also conform with NZS 5261, as applicable under local regulations.

## CONNECTION SIZES

- Hot water connection: RP $\frac{3}{4}$ /20
- Cold water connection: RP $\frac{3}{4}$ /20
- Relief valve connection: RP $\frac{1}{2}$ /15
- Gas inlet: RP $\frac{1}{2}$ /15 flared compression
- Gas regulator (propane models): RP $\frac{1}{2}$ /15 flared compression

## WATER INLET AND OUTLET

All pipe work must be cleared of foreign matter before connection and purged before attempting to operate the water heater. All olive compression fittings must use brass or copper olives. Use thread sealing tape or approved thread sealant on all fittings.

An isolation valve and non return valve must be installed on the cold water line to the water heater. An acceptable arrangement is shown in the diagram.

Refer also to **“Mains Water Supply”** on page 25 and to **“Hot Water Delivery”** on page 26.

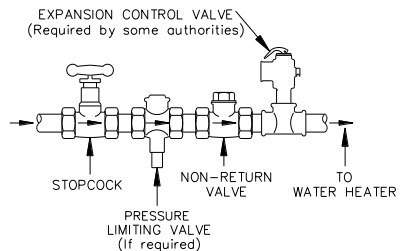

A disconnection union must always be provided at the cold water inlet and hot water outlet on the water heater to allow for disconnection of the water heater.

This water heater has either a plastic dip tube or fitting liner in the inlet and outlet fittings (see diagram). These must be in place for the water heater to function properly. Do not remove or damage them by using heat nearby. They will be pushed into the correct position as the fitting is screwed in.

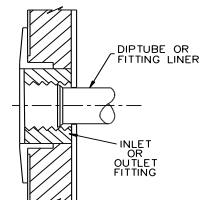



## PIPE SIZES

To achieve true mains pressure operation, the cold water line to the water heater should be the same size or bigger than the hot water line from the water heater.

The pipe sizing for hot water supply systems should be carried out by persons competent to do so, choosing the most suitable pipe size for each individual application. Reference to the technical specifications of the water heater and local regulatory authority requirements must be made.

## TEMPERATURE PRESSURE RELIEF VALVE

The temperature pressure relief valve is shipped behind the front cover. The temperature pressure relief valve must be fitted before the water heater is operated. Before fitting the relief valve, make sure the probe has not been bent. Seal the thread with Teflon tape - never hemp. Make sure the tape does not hang over the end of the thread.

Screw the valve into the correct opening (refer to the installation diagram on page 30) leaving the valve drain pointing downwards. Do not use a wrench on the valve body - use the spanner flats provided. A copper drain line must be fitted to the temperature pressure relief valve (refer to "Relief Valve Drain" on page 34).

The valve is supplied with an insulation collar. This must not be removed. The valve must be insulated with closed cell polymer insulation or similar (minimum thickness 9 mm) and the insulation installed so as not to impede the operation of the valve. The insulation must be weatherproof and UV resistant if exposed.

## EXPANSION CONTROL VALVE

Local regulations may make it mandatory to install an expansion control valve (ECV) in the cold water line to the water heater. In other areas, an ECV is required if the saturation index is greater than +0.4 (refer to "Water Supplies" on page 14).

The expansion control valve must always be installed after the non return valve and be the last valve installed prior to the water heater (refer to diagram on page 32). A copper drain line must be fitted to the expansion control valve (refer to "Relief Valve Drain" on page 34).

The valve must be insulated with closed cell polymer insulation or similar (minimum thickness 9 mm) and the insulation installed so as not to impede the operation of the valve. The insulation must be weatherproof and UV resistant if exposed.

### RELIEF VALVE DRAIN

DN15 copper drain lines must be fitted to the temperature pressure relief valve and expansion control valve (if one is installed) to carry the discharge clear of the water heater. Connect the drain lines to the valves using disconnection unions. The drain line from the valve to the point of discharge should be as short as possible, have a continuously downward fall all the way from the water heater to the discharge outlet and have no tap, valves or other restrictions in the pipe work.

A drain line from a relief valve must comply with the requirements of AS/NZS 3500.4.

A drain line must be no longer than 9 metres with no more than three bends greater than 45° before discharging at an outlet or air break. The maximum length of 9 metres for a drain line is reduced by 1 metre for each additional bend required of greater than 45°, up to a maximum of three additional bends. Where the distance to the point of final discharge exceeds this length, the drain line can discharge into a tundish.

Subject to local regulatory authority approval, the drain lines from the temperature pressure relief valve and expansion control valve from an individual water heater may be interconnected.

The outlet of a drain line must be in such a position that flow out of the pipe can be easily seen, but arranged so discharge will not cause injury, damage or nuisance. The termination point of a drain line must comply with the requirements of AS/NZS 3500.4. Drain lines must not discharge into a safe tray.

In locations where water pipes are prone to freezing, drain lines must be insulated, must not exceed 300 mm in length and are to discharge into a tundish through an air gap of between 75 mm and 150 mm.

If a drain line discharges into a tundish, the drain line from the tundish must be not less than DN20. The drain line from a tundish must meet the same requirements as for a drain line from a relief valve.

**⚠ Warning:** As the function of the temperature pressure relief valve on this water heater is to discharge high temperature water under certain conditions, it is strongly recommended the pipe work downstream of the relief valve be capable of carrying water exceeding 93°C. Failure to observe this precaution may result in damage to pipe work and property.

## GAS INLET

The gas connection is made through the left hand side near the access panel to the gas control. The pipe work must be cleared of foreign matter before connection and purged before attempting to light the water heater. An isolation valve and disconnection union must be installed to allow servicing and removal of the water heater.

**Natural gas models:** Remove the yellow warning label from the gas control valve.

**Propane gas models:** A regulator is supplied with the water heater and must be installed between the gas isolation valve and jacket of the water heater. The regulator has been preset to obtain a burner pressure of approximately 2.70 kPa. The regulator is adjustable.

- Remove the two protective plastic plugs, one at either end of the regulator, before installation.
- Refer to the gas flow directional arrow on the underside of the regulator to ensure it is installed in the correct orientation.

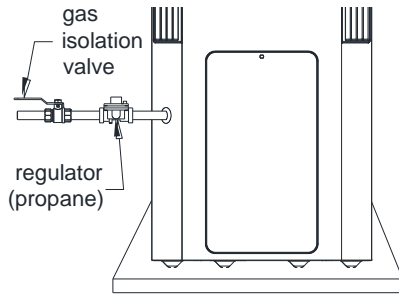

gas regulator - propane model

**Note:** Refer to the Gas Installations Standard AS 5601 or AS/NZS 5601.1 for the correct method of sizing the gas supply pipe to the water heater. The pipe size selection must take into account the gas input of this water heater (refer to table on page 31) as well as all of the other gas appliances in the premises.

**⚠ Warning:** Always isolate the water heater before pressure testing the gas supply system. Disconnect the water heater after the isolating cock to prevent the risk of serious damage to the gas control. The Everhot warranty does not cover damage of any nature resulting from failure to observe this precaution. Refer to the rating label for gas types and pressures.

**Caution:** Care is necessary when tightening fittings into the gas valve. The gas valve casting may crack if the fittings are over tightened. Cracked valve castings are not covered under the Everhot warranty. Damaged valves must be replaced.

---

# COMMISSIONING

---

## TO FILL AND TURN ON THE WATER HEATER

The gas pilot or burner must not be lit until the water heater is filled with water.

- Open all of the hot water taps in the house (don't forget the shower).
- Open the cold water isolation valve fully to the water heater.  
Air will be forced out of the taps.
- Close each tap as water flows freely from it.
- Check the pipe work for leaks.
- Open the gas isolation valve fully.
- Check the gas pipe work for leaks.
- Test the gas supply pressure to the water heater.  
Refer to “Gas Supply Pressure Testing” on page 37.
- Test the burner gas pressure and adjust if required.  
Refer to “Burner Gas Pressure Testing and Adjustment” on page 38.
- Light the water heater.  
Refer to “Lighting the Water Heater” on page 40.
- Test the water heater's burner operation.  
Refer to “Test the Water Heater after Installation” on page 42.
- Replace the access cover.

 **Warning:** Upon completion of the installation and commissioning of the water heater, leave this guide with the householder or responsible officer. **DO NOT** leave this guide inside of the cover of the water heater, as it may interfere with the safe operation of the water heater or ignite when the water heater is turned on.

Explain to the householder or a responsible officer the functions and operation of the water heater.

**GAS INLET PRESSURE**

**IMPORTANT – CHECK** the gas supply pressure at the inlet to the water heater with the water heater and all other gas burning appliances in the premises operating (burners alight). The minimum gas supply pressure is:

Natural Gas	1.13 kPa	Propane	2.75 kPa
-------------	----------	---------	----------

If this minimum cannot be achieved, it may indicate the meter or the gas line to the water heater is undersized. It is important to ensure that an adequate gas supply pressure is available to the water heater when other gas burning appliances, on the same gas supply, are operating.

**GAS SUPPLY PRESSURE TESTING**

To check and adjust the gas supply pressure to the water heater:

1. Ensure all other gas appliances in the premises are operating (burners alight).
2. Remove the access cover.
3. Close down the gas control valve (refer to “Close Down Procedure” on page 43) and close the gas isolation valve to the water heater.
4. Remove the screw from the inlet pressure test point on the left hand side of the gas control valve and attach the manometer hose to the test point (refer to the [gas control valve diagram](#) on page 38 for location).
5. Open the gas isolation valve fully.
6. Light the water heater and ensure the burner is operating (refer to “Lighting the Water Heater” on page 40).
7. Take the manometer reading (burner must be operating).  
The supply pressure must be above the minimum rating.
8. Close down the gas control valve (refer to “Close Down Procedure” on page 43) and close the gas isolation valve to the water heater.
9. Remove the manometer hose from the inlet pressure test point and replace test point screw.
10. Open the gas isolation valve fully.
11. Check the gas inlet pressure test point for leaks.
12. If the gas inlet pressure is correct, then check the burner gas pressure of the water heater. Refer to “Burner Gas Pressure Testing And Adjustment” on page 38.
13. If the minimum gas pressure cannot be obtained, check the size of the gas pipe to the water heater or if adjustment to the main gas supply regulator is required, then contact your local Gas Authority.

**BURNER GAS PRESSURE TESTING AND ADJUSTMENT**

The burner gas pressure must be checked and adjusted (if required) as part of the commissioning procedure. Refer to **Gas Details** table on page 31 or check the rating label of the water heater for the burner test point pressure with the burner operating.

To check and adjust the burner gas pressure of the water heater:

1. Remove the access cover.
2. Close down the gas control valve (refer to **“Close Down Procedure”** on page 43) and close the gas isolation valve to the water heater.

3. Using a small flat bladed screwdriver, lever and remove the black plastic cover surrounding the burner pressure test point on gas control.

4. Remove the screw from the burner pressure test point on the right side of the gas valve and attach the manometer hose to the test point.

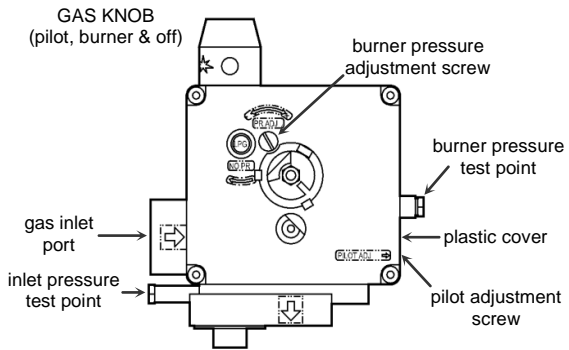

**Gas control valve (shown with thermostat dial removed)**

5. Open the gas isolation valve fully.
6. Light the water heater and ensure the burner is operating (refer to **“Lighting the Water Heater”** on page 40).
7. Take the manometer reading (burner must be operating).

The burner gas pressure should be:

- 1.0 kPa (±5%) for a natural gas model, or
- 2.7 kPa (±5%) for a propane model.

If adjustment is not required, proceed to step 9.

If adjustment is required, proceed to step 8.

8. **Natural gas model:** Remove the temperature adjusting dial from the front of the gas control valve by using a small flat bladed screwdriver to carefully lever the dial and pull away from the gas control valve.

Using a small flat bladed screwdriver, rotate the burner pressure adjustment screw (P.R.ADJ) clockwise to increase the burner pressure or anticlockwise to decrease the burner pressure until the manometer reads 1.0 kPa.

After adjusting the burner gas pressure refit the temperature adjusting dial.

**Propane gas model:** Remove the gas regulator cap from the top of the regulator by rotating anticlockwise using a flat bladed screwdriver.

Using a No. 2 Phillips head screwdriver, rotate the adjustment point clockwise to decrease or anticlockwise to increase the burner gas pressure until the manometer reads 2.7 kPa.

After adjusting the burner gas pressure refit the regulator cap.

**Note:** If the test point pressure cannot be adjusted to within 5% of the specified value for either a natural gas or propane gas model, complete this procedure and phone Rheem Service or their nearest Accredited Service Agent to arrange for an inspection.

9. Close down the gas control valve (refer to “Close Down Procedure” on page 43) and close the gas isolation valve to the water heater.
10. Remove the manometer hose from the burner pressure test point and replace test point screw.
11. Open the gas isolation valve fully.
12. Light the water heater and ensure the burner is operating (refer to “Lighting the Water Heater” on page 40).
13. Check the burner pressure test point for leaks.
14. Replace the black plastic cover surrounding the burner pressure test point on gas control by pushing back into position.
15. Replace the access cover.

#### TO TURN OFF THE WATER HEATER

If it is necessary to turn off the water heater on completion of the installation, such as on a building site or where the premises is vacant, then:

- Shut down the gas control (refer to “Close Down Procedure” on page 43).
- Close the gas isolation valve at the inlet to the gas control.
- Close the cold water isolation valve at the inlet to the water heater.

---

## LIGHTING THE WATER HEATER

---

### FOR YOUR SAFETY READ BEFORE LIGHTING

 **Warning:** This gas water heater is designed to operate reliably and safely as long as the operating instructions are followed **exactly**. You must comply with these lighting instructions at every stage.

**Make sure the water heater is filled with water and the water supply is on, otherwise serious damage to the vitreous enamel cylinder lining and plastic components may occur.**

The installer must check all gas connections for leaks, gas supply pressure and test point pressure (refer rating label). Remove the access panel at the front of the water heater to access the gas thermostat.

**Note:** AS 3498 requires that a water heater provides the means to inhibit the growth of Legionella bacteria in potable water. This water heater can satisfy this AS 3498 requirement provided it is operating and the thermostat setting is 60°C or higher, including when it is used as an in-series booster water heater for a solar water heater.

### SAFETY INFORMATION

- A. This water heater is equipped with a “Piezo” push button igniter which lights the pilot. When lighting the pilot follow these instructions exactly.
- B. **Before lighting** ensure there is no smell of gas around or in the vicinity of the water heater and the burner opening. Be sure to smell next to ground level as some gases can settle there.
- C. What to do if you smell gas.

Do not try to light the water heater.

If the gas smell is throughout the area, turn the gas control knob clockwise to the white dot “●” (off) position and then turn off the isolation valve on the gas line to the water heater. Leave the area and call Rheem Service or a qualified service technician.

- D. Use only your hand to turn the gas control knob, never use tools. If the control knob will not turn by hand, don't try to repair it, call a qualified service technician. Force or attempted repair may cause a fire or dangerous situation.
- E. Do not attempt to operate this water heater if it has been damaged. Call a qualified service technician.



**LIGHTING INSTRUCTIONS**

Using the gas control, light the water heater as follows:

1. **Stop**, read the “Safety Information” on page 40.

2. Remove the access cover.

3. Depress the GAS KNOB slightly and turn fully clockwise so the white dot “●” (off position) faces the front, aligning with gas knob position indicator.

4. Wait five (5) minutes so any build up of unburnt gas can escape. If you then smell gas, stop and follow “C” in the “Safety Information” on page 40. If you do not smell gas, proceed to step 5.

5. Depress the GAS KNOB slightly and turn anticlockwise so the red star “★” (pilot position) faces the front, aligning with gas knob position indicator.

6. Depress the GAS KNOB fully (until the red star disappears below the housing) and after 20 seconds, whilst keeping the GAS KNOB depressed, repeatedly press the igniter button (for up to 40 seconds) until the pilot flame ignites. The igniter is a red button located below and to the right of the gas control.

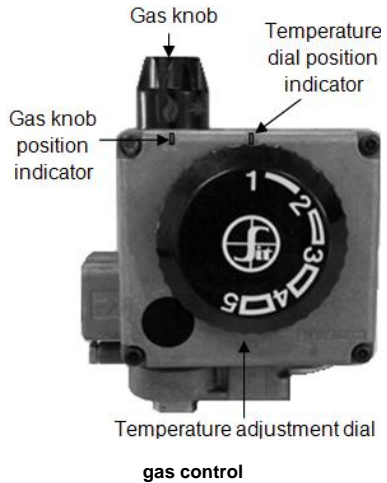

**⚠ Warning:** Keep your face clear of the combustion chamber opening while pressing the igniter.

**Note:** It is not possible to depress the GAS KNOB fully if the gas control has activated its safety shut-off feature. In this case, wait 5 minutes for the gas control to reset (this allows for any unburnt gas to escape).

7. Keep the GAS KNOB depressed for a further 20 seconds and then release.

8. Depress the GAS KNOB slightly and turn it anticlockwise so the red line “|” (ignition position) faces the front, aligning with gas knob position indicator, and hold there for 5 seconds.

9. Release the GAS KNOB (the GAS KNOB will automatically turn to the red flame “|” (on) position), and listen for the burner noise.

10. If the burner fails to light, depress the GAS KNOB slightly and turn it to the white dot “●” (off) position. Wait five (5) minutes for any unburnt gas to escape and then begin again at step 5.

**⚠ Warning:** Failure to wait five (5) minutes may result in a fire or dangerous situation.

11. When the burner remains alight with the GAS KNOB released, turn the temperature adjustment dial so the ‘4’ setting is at the top of the dial, aligning with temperature dial position indicator. This is the recommended setting and will give a water temperature of about 60°C.
12. Turn the adjusting dial past the ‘4’ position if a higher water temperature is required.
13. Replace the access cover.

The main burner will now automatically ignite when heating is required and extinguish when the water has been heated to the set temperature. If the main burner does not light at the selected setting, the water may already be at the selected temperature.

**Note:** Never press the igniter button while the top knob is in other than the red star “\*” (pilot) position (faces the front).

### TEST THE WATER HEATER AFTER INSTALLATION

The operation of the water heater must be thoroughly checked by the installer on completion of the installation.

- The burner flame must light smoothly and quickly from the pilot flame, and must go out quietly and completely.
- The main burner flame must be stable, although slight lifting at the front edge of the burner is acceptable when the burner is cold.
- The main burner flame should be blue, with a clearly defined inner cone - luminous yellow or "floating" flames are not acceptable.
- Check the test point pressure and compare with the rating label. Refer to “Gas Supply Pressure Testing” and “Burner Gas Pressure Testing and Adjustment” on pages 37 and 38. If the test point pressure cannot be adjusted to within 5% of the specified value, refer to Rheem Service or their nearest Accredited Service Agent.
- If unable to get the water heater working properly, contact Rheem Service or their nearest Accredited Service Agent.

When satisfied everything is working properly instruct the user in the correct method of operation.

**CLOSE DOWN PROCEDURE**

1. Remove the access cover.
2. Depress the GAS KNOB slightly and turn it clockwise so the red star “★” (pilot position) faces the front, aligning with gas knob position indicator.

This setting will leave the pilot flame alight, however the main burner will not be able to light.

To shut down the gas control completely, proceed to step 3.

**Note:** To reinstate the burner (from the red star “★” (pilot) position):

- Depress the GAS KNOB slightly and turn it anticlockwise so the red line “1” (ignition position) faces the front, aligning with gas knob position indicator, and hold there for 5 seconds.
- Release the GAS KNOB (the GAS KNOB will automatically turn to the red flame “🔥” (on) position) and the burner will ignite when heating is required and extinguish when the water in the storage cylinder has been heated to the set temperature.

If the main burner does not light at the selected setting, the water may already be at the selected temperature.

3. Depress the GAS KNOB slightly and turn it to the white dot “●” (off) position (faces the front), aligning with gas knob position indicator.

This setting shuts the gas control down completely.

**Note:** To relight the water heater, follow the “[Lighting Instructions](#)” on page 41.

4. Replace the access cover.

**Note:** When turned back on from the red star “★” (pilot) position or white dot “●” (off) position, the water heater may take up to an hour to reheat if the water has lost temperature.

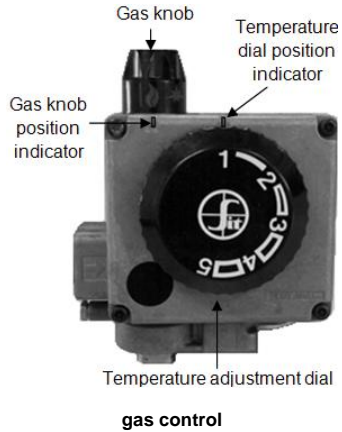

---

## DRAINING THE WATER HEATER

---

 **Warning:** Exercise care, as water discharged from the water heater may be of a very high temperature.

To drain the water heater:

- Turn off the water heater (refer to “**To Turn Off The Water Heater**” on page 39).
- Close all hot water taps.
- Operate the relief valve release lever - do not let the lever snap back or you will damage the valve seat.

Operating the lever will release the pressure in the water heater.

- Undo the union at the cold water inlet to the water heater and attach a hose to the water heater side of the union.

Let the other end of the hose go to a drain.

- Operate the relief valve again.

This will let air into the water heater and allow the water to drain through the hose.

---

This page is intentionally blank.

---

# EVERHOT GAS MAINS PRESSURE WATER HEATER WARRANTY – AUSTRALIA ONLY

---

## GAS WATER HEATER 647270 MODELS

### 1. THE EVERHOT WARRANTY – GENERAL

- 1.1 This warranty is given by Rheem Australia Pty Limited ABN 21 098 823 511 of 1 Alan Street, Rydalmere New South Wales, the manufacturer of Everhot mains pressure water heaters.
- 1.2 Rheem offer a trained and qualified national service network who will repair or replace components at the address of the water heater subject to the terms of the Everhot warranty. Rheem Service, in addition can provide preventative maintenance and advice on the operation of your water heater. The Rheem Service contact number is available 7 days a week on 131031 with Service personnel available to take your call from 8am to 8pm daily (hours subject to change).
- 1.3 For details about this warranty, you can contact us on 131031 or by email at [warrantyenquiry@rheem.com.au](mailto:warrantyenquiry@rheem.com.au) (not for service bookings).
- 1.4 The terms of this warranty are set out in section 2 and apply to water heaters manufactured after 1st January 2012.
- 1.5 If a subsequent version of this warranty is published, the terms of that warranty will apply to water heaters manufactured after the date specified in the subsequent version.

### 2. TERMS OF THE EVERHOT WARRANTY AND EXCLUSIONS TO IT

- 2.1 The decision of whether to repair or replace a faulty component is at Rheem's sole discretion.
- 2.2 If you require a call out and we find that the fault is not covered by the Everhot warranty, you are responsible for our standard call out charge. If you wish to have the relevant component repaired or replaced by Rheem, that service will be at your cost.
- 2.3 Where a failed component or cylinder is replaced under this warranty, the balance of the original warranty period will remain effective. The replacement does not carry a new Everhot warranty.
- 2.4 Where the water heater is installed outside the boundaries of a metropolitan area as defined by Rheem or further than 25 km from either a regional Rheem branch office or an Accredited Rheem Service Agent's office, the cost of transport, insurance and travelling between the nearest branch office or Rheem Accredited Service Agent's office and the installed site shall be the owner's responsibility.
- 2.5 Where the water heater is installed in a position that does not allow safe or ready access, the cost of that access, including the cost of additional materials handling and/or safety equipment, shall be the owner's responsibility. In other words, the cost of dismantling or removing cupboards, doors or walls and the cost of any special equipment to bring the water heater to floor or ground level or to a serviceable position is not covered by this warranty.
- 2.6 This warranty only applies to the original and genuine Everhot water heater in its original installed location and any genuine Everhot replacement parts.
- 2.7 The Everhot warranty does not cover faults that are a result of:
  - a) Accidental damage to the water heater or any component (for example: (i) Acts of God such as floods, storms, fires, lightning strikes and the like; and (ii) third party acts or omissions).

---

## EVERHOT GAS MAINS PRESSURE WATER HEATER WARRANTY – AUSTRALIA ONLY

---

- b) Misuse or abnormal use of the water heater.
  - c) Installation not in accordance with the Owner's Guide and Installation Instructions or with relevant statutory and local requirements in the State or Territory in which the water heater is installed.
  - d) Connection at any time to a water supply that does not comply with the water supply guidelines as outlined in the Owner's Guide and Installation Instructions.
  - e) Repairs, attempts to repair or modifications to the water heater by a person other than Rheem Service or a Rheem Accredited Service Agent.
  - f) Faulty plumbing or faulty gas supply.
  - g) Failure to maintain the water heater in accordance with the Owner's Guide and Installation Instructions.
  - h) Transport damage.
  - i) Fair wear and tear from adverse conditions (for example, corrosion).
  - j) Cosmetic defects.
- 2.8 Subject to any statutory provisions to the contrary, this warranty excludes any and all claims for damage to furniture, carpet, walls, foundations or any other consequential loss either directly or indirectly due to leakage from the water heater, or due to leakage from fittings and/ or pipe work of metal, plastic or other materials caused by water temperature, workmanship or other modes of failure.
- 2.9 If the water heater is not sized to supply the hot water demand in accordance with the guidelines in the Everhot water heater literature, any resultant fault will not be covered by the Everhot warranty.

### 3. WHAT IS COVERED BY THE EVERHOT WARRANTY FOR THE WATER HEATERS DETAILED IN THIS DOCUMENT

- 3.1 Rheem will repair or replace a faulty component of your water heater if it fails to operate in accordance with its specifications as follows:

What components are covered	The period in which the fault must appear in order to be covered	What coverage you receive
<b>All components</b>	Year 1	Repair and/or replacement of the faulty component, free of charge, including labour.
<b>The cylinder</b> (if the water heater is installed in a single-family domestic dwelling)	Years 2 to 7	Replacement cylinder, free of charge. Installation and repair labour costs are the responsibility of the owner.
<b>The cylinder</b> (if the water heater is <u>not</u> installed in a single-family domestic dwelling)	Years 2 & 3	Replacement cylinder, free of charge. Installation and repair labour costs are the responsibility of the owner.

---

# EVERHOT GAS MAINS PRESSURE WATER HEATER WARRANTY – AUSTRALIA ONLY

---

## GAS WATER HEATER 647270 MODELS

### 4. ENTITLEMENT TO MAKE A CLAIM UNDER THIS WARRANTY

- 4.1 To be entitled to make a claim under this warranty you need to:
- a) Be the owner of the water heater or have consent of the owner to act on their behalf
  - b) Contact Rheem Service without undue delay after detection of the defect and, in any event, within the applicable warranty period.
- 4.2 You are not entitled to make a claim under this warranty if your water heater:
- a) Does not have its original serial numbers or rating labels.
  - b) Is not installed in Australia.

### 5. HOW TO MAKE A CLAIM UNDER THIS WARRANTY

- 5.1 If you wish to make a claim under this warranty, you need to:
- a) Contact Rheem on 131031 and provide owner's details, address of the water heater, a contact number and date of installation of the water heater or if that's unavailable, the date of manufacture and serial number (from the rating label on the water heater).
  - b) Rheem will arrange for the water heater to be tested and assessed on-site.
  - c) If Rheem determines that you have a valid warranty claim, Rheem will repair or replace the water heater in accordance with this warranty.
- 5.2 Any expenses incurred in the making of a claim under this warranty will be borne by you.

### 6. THE AUSTRALIAN CONSUMER LAW

- 6.1 Our goods come with guarantees that cannot be excluded under the Australian Consumer Law. You are entitled to a replacement or refund for a major failure and for compensation for any other reasonably foreseeable loss or damage. You are also entitled to have the goods repaired or replaced if the goods fail to be of acceptable quality and the failure does not amount to a major failure.
- 6.2 The Everhot warranty (set out above) is in addition to any rights and remedies that you may have under the Australian Consumer Law.

**RHEEM AUSTRALIA PTY LTD**, A.B.N. 21 098 823 511, [www.rheem.com.au](http://www.rheem.com.au)  
For Service Telephone 131 031 AUSTRALIA 0800 657 335 NEW ZEALAND